



# Shape and local growth for multidimensional branching random walks in random environment

Francis Comets and Serguei Popov

Université Paris 7, UFR de Mathématiques, Case 7012, 2, Place Jussieu, F-75251, Paris Cedex 05, France

*E-mail address:* comets@math.jussieu.fr

*URL:* <http://www.proba.jussieu.fr/~comets>

Instituto de Matemática e Estatística, Universidade de São Paulo, Rua do Matão 1010, CEP 05508–090, São Paulo SP, Brazil

*E-mail address:* popov@ime.usp.br

*URL:* <http://www.ime.usp.br/~popov>

**Abstract.** We study branching random walks in random environment on the  $d$ -dimensional square lattice,  $d \geq 1$ . In this model, the environment has finite range dependence, and the population size cannot decrease. We prove limit theorems (laws of large numbers) for the set of lattice sites which are visited up to a large time as well as for the local size of the population. The limiting shape of this set is compact and convex, and the local size is given by a concave growth exponent. Also, we obtain the law of large numbers for the logarithm of the total number of particles in the process.

## 1. Introduction and results

We start with an informal description of the model we study in this paper. Particles live in  $\mathbb{Z}^d$  and evolve in discrete time. At each time, every particle is substituted by (possibly more than one) offspring which are placed in neighboring sites, independently of the other particles. The rules of offspring generation depend only on the location of the particle. The collection of those rules (so-called the *environment*) is itself random, it is chosen randomly before starting the process, and then it is kept fixed during all the subsequent evolution of the particle system.

---

*Received by the editors September 28, 2007; accepted November 13, 2007.*

*2000 Mathematics Subject Classification.* Primary 60K37; Secondary 60J80, 82D30.

*Key words and phrases.* Shape theorem, subadditive ergodic theorem, transience, growth exponent, population size.

Francis Comets was partially supported by CNRS (UMR 7599 “Probabilités et Modèles Aléatoires”) and by the “Réseau Mathématique France-Brésil”.

Serguei Popov was partially supported by CNPq (302981/02–0 and 471925/2006–3), FAPESP (04/07276–2), USP/COFECUB and by the “Rede Matemática Brasil-França”.

This model considered in this paper was introduced in Comets and Popov (2007). The random environment here affects both branching and transition mechanisms, and (as opposed to the models of Comets et al. (1998); Gantert and Müller (2006); Machado and Popov (2000, 2003)) the *immediate* descendants of a particle are not supposed to be independent. In Comets and Popov (2007) we proved a dichotomy for recurrence/transience, depending only on the support of the environmental law, and we gave sufficient conditions for recurrence and transience. In the recurrent case, the tails of the hitting times are studied and a shape theorem is obtained in a preliminary form. The recurrence/transience classification was later completed in Müller (2007b,a). We refer also to Baillon et al. (1993); Engländer (2005); den Hollander et al. (1999); Volkov (2001) for other work related to branching random walks in random environment.

Now, let us look at the subject of this paper from a different angle. For  $x \in \mathbb{Z}^d$ , let  $p(x, \cdot)$  be the transition probabilities from  $x$  to its nearest neighbors, and  $r(x) \geq 1$ . Consistently with the notation introduced later in this section, we denote by  $\omega = (\omega_x; x \in \mathbb{Z}^d)$  the collection of coefficients  $\omega_x = (p(x, x + \cdot), r(x))$  (as explained below,  $r(x)$  stands for the mean offspring in  $x$ ), and by  $\Delta^\omega$  the corresponding discrete Markov operator,

$$\Delta^\omega f(x) = \sum_{y \sim x} p(x, y)[f(y) - f(x)].$$

In this paper we will study for  $z \in \mathbb{Z}^d$  the solution  $u_n(x) = u_n^z(x)$  of the equation

$$\begin{cases} u_{n+1} - u_n = r\Delta^\omega u_n + (r-1)u_n, & x \in \mathbb{Z}^d, n = 0, 1, \dots, \\ u_0(x) = \mathbf{1}\{x = z\}. \end{cases} \quad (1.1)$$

It is easily checked, for instance by the discrete Feynman-Kac formula, that the solution  $u_n^z$  is given by the expectation  $u_n^z(x) = \mathbf{E}_\omega \eta_n^x(z)$  of the number  $\eta_n^x(z)$  of particles in  $z$  at time  $n$  in a discrete-time branching random walk starting from a single individual located at site  $x$  at time 0. The evolution rule of this branching random walk is that particles at  $x$  branch with an average of  $r(x)$  children which then move independently to a neighboring site randomly chosen from  $p(x, \cdot)$ . We will be interested in the case where the coefficients  $\omega$  are given by a stationary and finitely dependent random field. The model has other possible formulations. In the case of continuous time, the above equation becomes the parabolic partial differential equation

$$\frac{\partial}{\partial t} u_t(x) = \Delta^\omega u_t(x) + V^\omega(x)u_t(x)$$

with  $V^\omega(x)$  the branching rate. In our case the mean number of offspring is greater than or equal to 1 and bounded from above, or, equivalently,  $V^\omega(x)$  is nonnegative and bounded.

In the case where  $p(x, \cdot)$  are the simple random walk transition probabilities  $(1/2d, \dots, 1/2d)$ , so that  $\Delta$  is the standard Laplace operator, this equation is known as the parabolic Anderson problem, and has also continuous-space versions, see Sznitman (1998) and Sznitman (1994). These models have motivated a huge scientific activity, with particular interest on localization and intermittency (e.g. Gärtner et al. (2007); van der Hofstad et al. (2006)) and survival analysis (Antal (1995)), leading to fine pictures in the different cases of bounded or unbounded  $V$ 's. We stress that the Markov operator  $\Delta^\omega$  is random in the present

paper, a case that seems not to have been studied so far. Moreover,  $\Delta^\omega$  is non symmetric, this makes the model non-reversible with a possibly large drift, and prevents the use of a spectral theory as in the above references.

The present paper represents a step towards the understanding of the equation (1.1). We will prove that the solution  $u_n^z$  behaves like  $u_n^z(x) = \exp\{n\beta((z - x)/n) + o(n)\}$  as  $n \rightarrow +\infty$  (see Remark 1.8 where we comment on the function  $\beta$ ). We will even get into the finer study of the population size  $\eta_n^x(z)$  itself, and we prove the same asymptotics under the assumption that particles cannot die. Hence, the growth of the population is rather smooth at the coarse scale  $z - x = \mathcal{O}(n)$ . The occurrence of shape theorems and local growth rate goes back at least to Biggins (1978) and Laredo and Rouault (1983) for branching random walks, and to Greven and den Hollander (1992) in random environment. In fact, our model is slightly more general than described above. As mentioned in the beginning of this section, the branching and the displacement may be dependent. Also, the environment that we consider is not necessarily independent, but we allow for a finite range dependence. We believe that the results extend to more general dependence, but considering this case would require an important additional technical work.

**The model.** We now describe the model, keeping the notations of Comets and Popov (2007) whenever possible. Let  $\mathbb{Z}_+ = \{0, 1, 2, \dots\}$  and  $e_i$ -s be the coordinate vectors of  $\mathbb{Z}^d$ . We use the notation  $\|x\| = |x^{(1)}| + \dots + |x^{(d)}|$  for  $x = (x^{(1)}, \dots, x^{(d)}) \in \mathbb{R}^d$  (or  $x \in \mathbb{Z}^d$ ). Define the distance between two sets  $A, B \subset \mathbb{R}^d$  (or  $A, B \subset \mathbb{Z}^d$ ) by

$$\text{dist}(A, B) = \inf_{a \in A, b \in B} \|a - b\|.$$

Fix a finite set  $\mathfrak{A} \subset \mathbb{Z}^d$  such that  $\pm e_i \in \mathfrak{A}$  for all  $i = 1, \dots, d$ . Define

$$\mathcal{V} = \left\{ v = (v_x, x \in \mathfrak{A}) : v_x \in \mathbb{Z}_+, \sum_{x \in \mathfrak{A}} v_x \geq 1 \right\},$$

and for  $v \in \mathcal{V}$  put  $|v| = \sum_{x \in \mathfrak{A}} v_x$ ; note that  $|v| \geq 1$  for all  $v \in \mathcal{V}$ . Furthermore, let  $\mathcal{M}$  be the set of all probability measures  $\omega$  on  $\mathcal{V}$ :

$$\mathcal{M} = \left\{ \omega = (\omega(v), v \in \mathcal{V}) : \omega(v) \geq 0 \text{ for all } v \in \mathcal{V}, \sum_{v \in \mathcal{V}} \omega(v) = 1 \right\}.$$

Then, suppose that  $\omega := (\omega_x \in \mathcal{M}, x \in \mathbb{Z}^d)$  is a stationary ergodic random field, and denote by  $\mathbb{P}, \mathbb{E}$  the probability and expectation with respect to  $\omega$ . Throughout this paper we suppose that this field is also *finitely dependent*, that is, the following condition holds:

**Condition I.** There exists a positive number  $\varrho$  such that for any two sets  $A, B \subset \mathbb{Z}^d$  with  $\text{dist}(A, B) \geq \varrho$  the following holds: the sigma-algebra generated by  $(\omega_x, x \in A)$  is independent under  $\mathbb{P}$  from the sigma-algebra generated by  $(\omega_x, x \in B)$ . Note that  $\varrho = 1$  corresponds to the case of independent identically distributed environment.

The collection  $\omega = (\omega_x, x \in \mathbb{Z}^d)$  is called *the environment*. Given the environment  $\omega$ , the evolution of the process is described in the following way: start with one particle at some fixed site of  $\mathbb{Z}^d$ . At each integer time the particles branch independently using the following mechanism: for a particle at site  $x \in \mathbb{Z}^d$ , a random element  $v = (v_y, y \in \mathfrak{A})$  is chosen with probability  $\omega_x(v)$ , and then the particle is substituted by  $v_y$  particles in  $x + y$  for all  $y \in \mathfrak{A}$ . Note that the population never gets extinct, since every individual has at least one direct descendant.

For the process starting from one particle at  $x$ , let us denote by  $\eta_n^x(y)$  the number of particles in  $y$  at time  $n$ . Define the random variable

$$\mathcal{Z}_n^x = \sum_{y \in \mathbb{Z}^d} \eta_n^x(y),$$

i.e.,  $\mathcal{Z}_n^x$  is the total number of particles at moment  $n$  for the process starting from  $x$ .

We denote by  $\mathbb{P}_\omega^x, \mathbf{E}_\omega^x$  the (so-called “quenched”) probability and expectation for the process starting from  $x$  in the fixed environment  $\omega$ . We use the notation  $\mathbf{P}^x[\cdot] = \mathbb{E}\mathbb{P}_\omega^x[\cdot]$  for the annealed law of the branching random walk in random environment, and  $\mathbf{E}^x$  for the corresponding expectation. Also, sometimes we use the symbols  $\mathbb{P}_\omega, \mathbf{E}_\omega, \mathbf{P}, \mathbf{E}$  without the corresponding superscripts when it can create no confusion (e.g. when the starting point of the process is indicated elsewhere).

Throughout this paper, and often without recalling it explicitly, we suppose that the two conditions below are fulfilled:

**Condition B.**

$$\mathbb{P}[\text{there exists } v \in \mathcal{V} \text{ such that } \omega_0(v) > 0 \text{ and } |v| \geq 2] > 0.$$

**Condition UE.** For some  $\varepsilon_0 > 0$ ,

$$\mathbb{P}\left[\sum_{v: v_e \geq 1} \omega_0(v) \geq \varepsilon_0 \text{ for any } e \in \{\pm e_1, \dots, \pm e_d\}\right] = 1.$$

Condition B ensures that the model cannot be reduced to random walk without branching, and Condition UE is a natural uniform ellipticity condition which ensures that the walk is really  $d$ -dimensional. In this paper, the weaker ellipticity Condition E of Comets and Popov (2007) will usually not be enough for our purposes. In fact, we believe that most of our results do not generally hold if one only assumes Condition E.

For technical reasons we need also the following two conditions:

**Condition D.** There exists a positive constant  $D_0$  such that the expectation of the total number of the immediate descendants of any particle is at most  $D_0$ , i.e.,  $\mathbb{P}[\sum_{v \in \mathcal{V}} |v| \omega_0(v) \leq D_0] = 1$ .

**Condition A.** There exist  $x \in \mathfrak{A}, v \in \mathcal{V}$  with  $\|x\|$  even and  $v_x \geq 1$  such that  $\mathbb{P}[\omega_0(v) > 0] > 0$ .

We refer to Condition A as the “aperiodicity condition” because, without it, the process starting from the origin would live on even sites at even times, and on odd sites at odd times. If (with  $x, v$  of Condition A) a site  $y$  is such that  $\omega_y(v) > 0$ , we say that this site is an *aperiodic* site, and when  $\omega_y(v) > \delta$ , we say that this site is  $\delta$ -aperiodic. We briefly mention that suitably adjusted versions of all our results are also true without Condition A; the proofs are either the same or even simpler, since we do not have to care about searching for the aperiodic sites, e.g. the proofs of Theorems 1.4 and 1.7.

**Remark 1.1.** A particular case of the model considered here is the usual construction of the branching random walk, that was already mentioned in the beginning of this paper: for each  $x$ , specify the transition probabilities  $p(x, y)$ ,  $y \in \mathfrak{A}$ , and branching probabilities  $r_i(x)$ ,  $i = 1, 2, 3, \dots$ . A particle in  $x$  is first substituted by  $i$  particles with probability  $r_i(x)$ , then each of the offspring jumps independently

to  $x + y$  with probability  $p(x, y)$ . The pairs  $((r_i(x))_{i \geq 1}, (p(x, y))_{y \in \mathfrak{A}})$  are chosen according to some i.i.d. field on  $\mathbb{Z}^d$ . In our notations,  $\omega_x$  is a mixture of multinomial distributions on  $\mathfrak{A}$ :

$$\omega_x(\cdot) = \sum_{i \geq 1} r_i(x) \text{Mult}(i; p(x, y), y \in \mathfrak{A})(\cdot).$$

**Statement of the results.** All through the paper, we will assume the above five conditions. Following Comets and Popov (2007), we define the notions of transience and recurrence:

**Definition 1.2.** *For the particular realization of the random environment  $\omega$ , the branching random walk is called recurrent if*

$$\mathbb{P}_\omega^0[\text{the origin is visited infinitely often}] = 1.$$

*Otherwise, the branching random walk is called transient.*

The following result is a consequence of Propositions 1.2, 1.3, and Theorem 1.6 of Comets and Popov (2007), and also Theorem 3.2 of Müller (2007a); in Section 2.1, we comment about the validity of (i) and (ii) below in the non-i.i.d. case  $\varrho > 1$ .

**Proposition 1.3.** *We have either:*

- (i) *For  $\mathbb{P}$ -almost all  $\omega$ , the branching random walk is recurrent, in which case  $\mathbb{P}_\omega^x[\text{the origin is visited infinitely often}] = 1$  for all  $x \in \mathbb{Z}^d$ , or:*
- (ii) *For  $\mathbb{P}$ -almost all  $\omega$ , the branching random walk is transient, in which case  $\mathbb{P}_\omega^x[\text{the origin is visited infinitely often}] = 0$  for all  $x \in \mathbb{Z}^d$ .*

*The classification criterion: In the case of an i.i.d. environment, i.e.,  $\varrho = 1$ , the branching random walk in random environment is transient if and only if there exist  $s \in \mathbb{R}^d \setminus \{0\}$  and  $\lambda > 0$  such that  $\mathbb{P}$ -almost surely we have*

$$\sum_{y \in \mathfrak{A}} \mu_y^\omega \lambda^{y \cdot s} \leq 1, \tag{1.2}$$

where  $\mu_y^\omega = \mathbb{E}_\omega \eta_1^0(y)$  is the mean number of particles sent to  $y \in \mathfrak{A}$  by one particle at the origin.

It is interesting to observe that, in the case of an i.i.d. environment, one has a simple explicit criterion of transience/recurrence for the branching random walk in random environment; however, for the many-dimensional random walk *without branching* in random environment the problem of finding such a criterion is still far from being solved. In Comets and Popov (2007) one can find more evidence that branching makes random walks in random environment “simpler”; see, for instance, the results about the tails of first hitting times.

Now, we are ready to formulate the main results of this paper. In what follows, for any  $A \subset \mathbb{R}^d$ ,  $\bar{A}$  is the closure of  $A$ , and  $A^\circ$  is the interior of  $A$ .

First, we obtain a shape result about the sites that *can* contain a particle at time  $n$ .

**Theorem 1.4.** *There exists a compact convex set  $F \subset \mathbb{R}^d$  such that for any  $\varepsilon > 0$ , for almost all  $\omega$  there exists  $n(\omega, \varepsilon)$  such that*

$$\mathbb{P}_\omega[\eta_m^0(x) = 0 \text{ for all } x \in \mathbb{Z}^d \setminus (1 + \varepsilon)mF] = 1 \tag{1.3}$$

and

$$\mathbb{P}_\omega[\eta_m^0(x) = 0] < 1 \quad \text{for all } x \in \mathbb{Z}^d \cap (1 - \varepsilon)mF \quad (1.4)$$

for all  $m \geq n(\omega, \varepsilon)$ .

Next, we characterize the (quenched) mean local number of particles.

**Theorem 1.5.** *There exists a convex downwards, continuous function  $\beta : F^\circ \rightarrow \mathbb{R}$  such that for any closed  $G \subset F^\circ$*

$$\max_{x \in nG \cap \mathbb{Z}^d} |n^{-1} \ln \mathbf{E}_\omega \eta_m^0(x) - \beta(x/n)| \rightarrow 0 \quad \mathbb{P}\text{-a.s.}, \quad (1.5)$$

as  $n \rightarrow \infty$ .

The function  $\beta$  is called the local growth exponent for the branching random walk. Denote  $B = \{x \in \mathbb{R}^d : \beta(x) \geq 0\}$ ; by the convexity of  $\beta$ , the set  $B$  is compact and convex. All through, convex functions will mean convex downwards.

**Theorem 1.6.** *The branching random walk in random environment is recurrent if and only if  $\beta(0) > 0$ .*

Note that the border case  $\beta(0) = 0$  is transient. Note also that, from the property (1.7) below, one obtains that  $\beta(0) > 0$  if and only if  $0 \in B^\circ$ . Thus, given  $B$ , one can determine whether the branching random walk is recurrent or transient.

The next result does not only tell us, similarly to Theorem 1.10 of Comets and Popov (2007), where the particles are located at time  $n$ , but it also gives an important information about the local size of the population.

**Theorem 1.7.** *For any closed  $G \subset B^\circ$ ,*

$$\max_{x \in nG \cap \mathbb{Z}^d} |n^{-1} \ln \eta_n^0(x) - \beta(x/n)| \rightarrow 0 \quad (1.6)$$

as  $n \rightarrow \infty$ , a.s.

**Remark 1.8.** (*Equivalence of models.*) The local growth exponent  $\beta$  is defined by (1.5). By definition it only depends on the quenched expectation of the number of particles, and further, only on the mean number  $\mu_y^\omega$  of particles sent in one step to  $y$  by one particle at the origin. Indeed,

$$\mathbf{E}_\omega \eta_n^0(x) = \sum \prod_{i=1}^n \mu_{x_i - x_{i-1}}^{\omega^{(i)}}$$

where  $\omega^{(i)}$  is the environment shifted by  $x_{i-1}$ , and where the sum ranges over all sequences  $(x_i; 0 \leq i \leq n)$  with  $x_0 = 0, x_n = x, x_i - x_{i-1} \in \mathfrak{A}$ . In particular, for any mapping  $\omega \mapsto \tilde{\omega}$  from  $\mathcal{M}$  to itself such that  $\mu_y^\omega = \mu_y^{\tilde{\omega}}$  for all  $y \in \mathfrak{A}, \omega \in \mathcal{M}$ , the two branching random walks in the environments  $\omega$  and  $\tilde{\omega}$  are equivalent, in the sense that they have the same local behavior at the logarithmic scale. Fine details of the branching and displacement do not matter, under the above five conditions. Moreover, for results that only concern the expected number of particles (such as Theorem 1.5) we really do not need the assumption that any particle produces at least one offspring; this can be substituted by a weaker assumption  $\mathbf{E}_\omega \mathcal{Z}_1^0 \geq 1$   $\mathbb{P}$ -a.s.

Finally, we formulate a result about the total size of the population:

**Theorem 1.9.** *The function  $\beta$  has the property*

$$\sup_{x \in F^o} \beta(x) > 0. \tag{1.7}$$

*For the total size of the population  $Z_n^0$ , it holds that*

$$\frac{\ln Z_n^0}{n} \rightarrow \sup_{x \in F^o} \beta(x) \tag{1.8}$$

*a.s., as  $n \rightarrow \infty$ .*

Note that, by (1.7),  $B \neq \emptyset$ , and  $B^o \neq \emptyset$  by convexity. From Theorems 1.5 and 1.7 it follows that for  $\mathbb{P}$ -almost all  $\omega$ , for any  $\varepsilon > 0$

$$\mathbb{P}_\omega[\text{for all } m \text{ large enough } \eta_m^0(x) = 0 \ \forall x \in (1 + \varepsilon)mB, \\ \eta_m^0(x) \geq 1 \ \forall x \in (1 - \varepsilon)mB] = 1.$$

As opposed to Theorem 1.10 of Comets and Popov (2007), here we prove this result both in transient and recurrent cases.

**Example 1.10. (Constant branching)** More information can be obtained in the particular case when there exists a constant  $\mu > 1$  such that

$$\sum_{y \in \mathfrak{A}} \mu_y^\omega = \mu \quad \mathbb{P}\text{-a.s.}$$

In this case, the expected size of the population is  $\mathbb{E}_\omega Z_n^0 = \mu^n$ . This is the case for instance when  $\mu_y^\omega$  does not depend on  $\omega$ , and then the branching random walk is equivalent to a tree-indexed Markov chain (since in this case we can suppose also that the immediate descendants jump independently, and the offspring distribution does not depend on the site, cf. Remark 1.8). In the general case, we can define the transitions

$$p^{\omega_0}(y) = \frac{\mu_y^\omega}{\mu}, \quad y \in \mathfrak{A}$$

(recall that  $\mu_y^\omega$  only depends on  $\omega_0$ ), and consider the random walk in random environment  $\chi_n$  with transition probabilities  $\mathbb{P}_\omega[\chi_{n+1} = x+y \mid \chi_n = x] = p^{\omega_x}(y)$  for  $y \in \mathfrak{A}$ . We see here that  $\mathbb{E}_\omega \eta_n^0(x) = \mu^n \mathbb{P}_\omega(\chi_n = x)$ , and therefore, by Theorem 1.5,

$$\beta(a) = \ln \mu + \lim_{n \rightarrow \infty} n^{-1} \ln \mathbb{P}_\omega[\chi_n = [na]]$$

with  $[na]$  the integer part of  $na$  (coordinatewise). The limit can be expressed in terms of the quenched large deviation rate function  $I^q$ , which have been studied in the nestling case in Zerner (1998) and in complete generality in Varadhan (2004): it holds that

$$\beta(a) = \ln \mu - I^q(a).$$

These references are for i.i.d. environment and estimate the probability of sets in the scale  $n$  instead of the probability of points, but one can see that they apply to our discussion here. This example shows that the convex function  $\beta$  is not necessarily strictly convex. Indeed, it is known that the rate function has a flat horizontal part if the random walk in random environment is nestling with a non-zero speed  $v$ , in which case  $I^q(a) = 0$  for  $a$  in the whole interval with endpoints 0 and  $v$ . Finally, it is straightforward to see from the nearest neighbor jumps case, that the shapes  $F$  and  $B$  may have “facets”, i.e., flat parts on their boundaries (cf. e.g. Example 7 of Comets and Popov (2007)).

## 2. Proofs

The rest of this paper is organised as follows. First, in Section 2.1 we recall some concepts from Comets and Popov (2007), such as recurrent seeds and induced random walks. In Section 2.2 we study the set of sites which can be reached up to time  $n$  (this amounts, basically, to applying the Subadditive Ergodic Theorem). In Section 2.3 we prove the results related to the *expected* local population size, and in Section 2.4 we study the local population size itself. Finally, in Section 2.5 we prove the equation (1.7), i.e., that the expectation of the total number of particles grows exponentially (somewhat surprisingly, this is one of the most difficult results of this paper), and then we prove Theorem 1.9.

**2.1. Induced random walks.** To begin, we introduce some more basic notations. We denote by  $\mathbb{Q}$  the set of rational numbers, and define  $\mathbb{N} := \{1, 2, 3, \dots\}$ . Let  $L_0$  to be the maximal jump length, i.e.,

$$L_0 = \max_{x \in \mathfrak{A}} \|x\|,$$

and let  $\mathcal{K}_n$  be the  $d$ -dimensional discrete ball with respect to the  $\ell_1$ -norm:

$$\mathcal{K}_n = \{x \in \mathbb{Z}^d : \|x\| \leq n\}. \quad (2.1)$$

As in Section 2.1 of Comets and Popov (2007), we define now the notion of *induced* random walk in random environment associated with the branching random walk in random environment. Defining

$$\tilde{\mathcal{V}} = \{(v, \kappa) : v \in \mathcal{V}, \kappa \text{ probability measure on } \{y : v(y) \geq 1\}\},$$

we consider some probability measure  $\tilde{\mathbb{P}}$  on  $\tilde{\mathcal{V}}^{\mathbb{Z}^d}$  with marginal  $\mathbb{P}$  on  $\mathcal{V}^{\mathbb{Z}^d}$ . A stationary random field  $\tilde{\omega} = ((\omega_x, \kappa_x), x \in \mathbb{Z}^d)$  with the law  $\tilde{\mathbb{P}}$  defines our branching random walk as above, coupled with a random walk in random environment with transition probability

$$p_x(y) = \sum_{v \in \mathcal{V}} \omega_x(v) \kappa_x(y) \quad (2.2)$$

from  $x$  to  $x + y$ . In words, we pick randomly one of the children in the branching random walk. To keep things simple, we will drop the tilde from the notations  $\tilde{\mathbb{P}}$ . In this paper, we need only the so-called uniform induced random walk, for which the measure  $\kappa$  is defined as follows:  $\kappa$  is uniform on the locations  $\{x \in \mathfrak{A} : v_x \geq 1\}$ .

An important idea that will be repeatedly employed in this paper is to use the uniform ellipticity of the walk in order to reveal some independence in the environment: because of Condition UE, the uniform induced random walk is uniformly elliptic as well, and so sometimes it makes its steps “without looking at the environment”. A similar construction can be found in Comets and Zeitouni (2004); Zeitouni (2004). Specifically, let us consider the uniform induced random walk  $\xi^z$  ( $z$  stands for the starting location of this random walk). According to (2.2), the transition probabilities for  $\xi^z$  are:

$$\sigma(x, x + y) = \mathbb{P}_\omega[\xi_{n+1}^z = x + y \mid \xi_n^z = x] = \sum_{v: v_y \geq 1} \frac{\omega_x(v)}{|\{u : v_u \geq 1\}|},$$

which means that, in the case when a particle has more than one offspring in the branching random walk (i.e., it produces a configuration  $v$  with  $|v| > 1$ ), the next (relative) location for the uniform induced random walk is chosen uniformly among



the locations  $\{x \in \mathfrak{A} : v_x \geq 1\}$ . By Condition UE, this induced random walk is uniformly elliptic in the sense that

$$\mathbb{P}_\omega[\xi_{n+1}^z = x + e \mid \xi_n^z = x] \geq \hat{\varepsilon}_0 \quad \text{for all } e \in \{\pm e_i, i = 1, \dots, d\}$$

where  $\hat{\varepsilon}_0 = \varepsilon_0/|\mathfrak{A}|$ . Let  $\hat{Z}_1, \hat{Z}_2, \hat{Z}_3, \dots$  be a sequence of i.i.d. random variables with values in  $\{0, 1, \dots, 2d\}$ , such that  $\mathbb{P}_\omega[\hat{Z}_i = j] = \hat{\varepsilon}_0$  for  $j \neq 0$  and of course  $\mathbb{P}_\omega[\hat{Z}_i = 0] = 1 - 2d\hat{\varepsilon}_0$ . We still keep the symbol  $\mathbb{P}_\omega$  to denote the probability on the enlarged probability space where both the branching random walk and the sequence  $(\hat{Z}_i)_i$  are defined. Set  $Z_i = \mathbf{1}\{\hat{Z}_i \neq 0\}$ . Let us enumerate the elements of the set  $\{\pm e_i, i = 1, \dots, d\}$  in some order, so that  $\{\pm e_i, i = 1, \dots, d\} = \{\hat{e}_i, i = 1, \dots, 2d\}$ . We can now construct the induced random walk as follows:

- if  $\hat{Z}_i = j$  for some  $j \neq 0$ , then  $\xi_i^z = \xi_{i-1}^z + \hat{e}_j$ ;
- if  $\hat{Z}_i = 0$ , then  $\xi_i^z = \xi_{i-1}^z + \hat{e}_j$  with probability  $\frac{\sigma(\xi_{i-1}^z, \xi_{i-1}^z + \hat{e}_j) - \hat{\varepsilon}_0}{1 - 2d\hat{\varepsilon}_0}$ , and  $\xi_i^z = \xi_{i-1}^z + y$  with probability  $\frac{\sigma(\xi_{i-1}^z, \xi_{i-1}^z + y)}{1 - 2d\hat{\varepsilon}_0}$  for  $y \notin \{\hat{e}_i, i = 1, \dots, 2d\}$ .

In words, this means that when the value of  $Z$ -variable is 1, the random walk moves without looking at the random environment.

In the next definition we recall the notion of  $(U, \mathcal{H})$ -seed (suitably adapted for the case of finitely dependent environment), that was introduced in Comets and Popov (2007).

**Definition 2.1.** Fix a finite set  $U \subset \mathbb{Z}^d$  containing 0, and  $\mathcal{H}_x \subset \mathcal{M}$  with  $\mathbb{P}[\omega_x \in \mathcal{H}_x \text{ for all } x \in U] > 0$ . With  $\mathcal{H} = (\mathcal{H}_x, x \in U)$ , the pair  $(U, \mathcal{H})$  is called a seed. We say that  $\omega$  has a  $(U, \mathcal{H})$ -seed at  $z \in \mathbb{Z}^d$  (or that a  $(U, \mathcal{H})$ -seed occurs in  $z$ ) if

$$\omega_{z+x} \in \mathcal{H}_x \text{ for all } x \in U,$$

and that  $\omega$  has a  $(U, \mathcal{H})$ -seed in the case  $z = 0$ . We call  $z$  the center of the seed.

As in Comets and Popov (2007), it is easy to see that with probability 1 the branching random walk visits infinitely many distinct  $(U, \mathcal{H})$ -seeds (this can be done by showing that the uniform induced random walk does so). We now give the argument. With  $r = \varrho + \text{diameter}(U)$ , at any time a.s. there exist subsequent times  $n, t = n + r$  such that at time  $t$  the uniform induced random walk is situated in a location  $x$  which is at distance  $r$  away from its range up to time  $n$ , without looking at the environment (that is,  $Z_{n+1} = \dots = Z_t = 1$ ). Then, by Condition I, the environment can be constructed inside the translate  $x + U$  independently from all what done before, and so the probability to generate a  $(U, \mathcal{H})$ -seed at site  $x$  is a positive constant. By the Borel-Cantelli lemma, with probability 1 an infinite number of  $(U, \mathcal{H})$ -seeds will be visited.

Then, still following Comets and Popov (2007), we define the branching random walk restricted to set  $M \subset \mathbb{Z}^d$  simply by discarding all particles that step outside  $M$ , and write  $\mathbb{P}_{\omega|M}, \mathbf{E}_{\omega|M}$  for corresponding probability and expectation. Next, we consider a shortened version of Definition 2.5 from Comets and Popov (2007):

**Definition 2.2.** Let  $U$  be a finite subset of  $\mathbb{Z}^d$  with  $0 \in U$ . Let  $\mathbf{p}$  be a probability distribution on  $\mathbb{Z}_+$  with mean larger than 1, i.e.,  $\mathbf{p} = (p_0, p_1, p_2, \dots)$  with  $p_i \geq 0$ ,  $\sum p_i = 1$ ,  $\sum ip_i > 1$ . An  $(U, \mathcal{H})$ -seed is called  $\mathbf{p}$ -recurrent if for any  $\omega$  such that  $\omega_x \in \mathcal{H}_x, x \in U$ , we have

$$\mathbb{P}_{\omega|U}^0[0 \text{ will be visited by at least } i \text{ "free" particles}] \geq \sum_{j=i}^{\infty} p_j$$

for all  $i \geq 1$ . By “free” particles we mean that none is the descendant of another one.

It is important to note that, by definition of the restricted branching random walk, the above probability only depends on the environment inside the  $\varrho$ -neighborhood of  $U$ .

Then, it is straightforward to see that all the discussion of Section 2.2 of Comets and Popov (2007) readily extends to the case of finitely dependent environment as well. In particular, the recurrence is equivalent to the existence of recurrent seeds; this fact will be used several times in this paper.

2.2. *Proof of Theorem 1.4.* For arbitrary  $x, y \in \mathbb{Z}^d$ ,  $\delta \in [0, \varepsilon_0]$  ( $\varepsilon_0$  is from Condition UE), define

$$T_\omega^\delta(x, y) = \min\{n : \text{there exist } z_0, z_1, \dots, z_n \in \mathbb{Z}^d \text{ with } z_0 = x, z_n = y \\ \text{such that } \omega_{z_i}(v : v_{z_{i+1}-z_i} \geq 1) > \delta, \quad i = 0, \dots, n-1\},$$

so that  $T_\omega^\delta(x, y)$  is the minimal number of steps necessary for a particle in  $x$  to send an offspring to  $y$ , with the condition also that this should happen with big enough probability on each step. By Condition UE, it is immediate that

$$T_\omega^\delta(x, y) \leq \|x - y\|. \tag{2.3}$$

Clearly, this family of random variables has the subadditive property: for any  $x, y, z \in \mathbb{Z}^d$ ,  $\delta \in [0, \varepsilon_0]$ , and any  $\omega$

$$T_\omega^\delta(x, y) \leq T_\omega^\delta(x, z) + T_\omega^\delta(z, y). \tag{2.4}$$

Consider any  $a \in \mathbb{Q}^d$  and define

$$\mu^\delta(a) = \lim_{n \rightarrow \infty} \frac{T_\omega^\delta(0, k_0 a n)}{k_0 n}, \tag{2.5}$$

where  $k_0$  is the smallest positive integer such that  $k_0 a \in \mathbb{Z}^d$ . With (2.3) and (2.4), the Subadditive Ergodic Theorem (see e.g. Theorem 2.6 of Chapter VI of Liggett (1985)) shows that the (nonrandom) limit in (2.5) exists a.s. and in  $\mathcal{L}_1$ ; by (2.4), this limit verifies  $\mu^\delta(a) + \mu^\delta(b) \geq \mu^\delta(a + b)$ ,  $\mu^\delta(ra) = r\mu^\delta(a)$ , for any  $a, b \in \mathbb{Q}^d, r \in \mathbb{Q}^+$ . Moreover, since the jumps are bounded, we have  $T_\omega^\delta(x, y) \geq L_0^{-1}\|x - y\|$  and finally  $L_0^{-1}\|a\| \leq \mu^\delta(a) \leq \|a\|$ . Then, by continuity one can define  $\mu^\delta(a)$  for any  $a \in \mathbb{R}^d$  in such a way that  $\mu^\delta$  is a norm on  $\mathbb{R}^d$ .

Let

$$F_\delta = \{a \in \mathbb{R}^d : \mu^\delta(a) \leq 1\}.$$

Clearly, for any  $\delta \in [0, \varepsilon_0]$ , the set  $F_\delta$  is compact and convex, and  $0 \in F_\delta^o$ . By definition, for any  $x, y$  and  $\omega$  it holds that

$$T_\omega^{\delta_1}(x, y) \leq T_\omega^{\delta_2}(x, y) \tag{2.6}$$

when  $\delta_1 \leq \delta_2$ . So, we have that  $F_{\delta_1} \subset F_{\delta_2}$  for  $\delta_1 \geq \delta_2$ . For the rest of this paper, denote  $F := F_0$  (and this is the compact convex set we are looking for in Theorem 1.4). The following lemma shows that the family  $F_\delta$  is continuous in  $\delta$ :

**Lemma 2.3.** *For any  $\varepsilon > 0$  there exists  $\delta > 0$  such that  $(1 - \varepsilon)F \subset F_\delta \subset F$ .*

*Proof:* By covering  $F$  with finitely many small disks, we see it is enough to prove that, for any  $a \in \mathbb{Q}^d$ ,

$$\lim_{\delta \rightarrow 0} \left[ \lim_{n \rightarrow \infty} \frac{T_\omega^\delta(0, k_0 a n)}{k_0 n} - \lim_{n \rightarrow \infty} \frac{T_\omega^0(0, k_0 a n)}{k_0 n} \right] = 0, \tag{2.7}$$

where  $k_0$  is the smallest positive integer such that  $k_0 a \in \mathbb{Z}^d$ . Observe that, by the Subadditive Ergodic Theorem, the left-hand side of (2.7) is equal to

$$\lim_{\delta \rightarrow 0} \left[ \inf_{n \geq 1} \frac{\mathbb{E}T_\omega^\delta(0, k_0 a n)}{k_0 n} - \inf_{n \geq 1} \frac{\mathbb{E}T_\omega^0(0, k_0 a n)}{k_0 n} \right].$$

Note that, by (2.3),  $T_\omega^\delta(x, y)$  depends only on a finite piece of the environment, so

$$\mathbb{E}T_\omega^\delta(x, y) \rightarrow \mathbb{E}T_\omega^0(x, y) \tag{2.8}$$

as  $\delta \rightarrow 0$ . Now, fix an arbitrary  $\varepsilon > 0$  and choose  $n_1$  in such a way that

$$\frac{\mathbb{E}T_\omega^0(0, k_0 a n_1)}{k_0 n_1} - \inf_{n \geq 1} \frac{\mathbb{E}T_\omega^0(0, k_0 a n)}{k_0 n} < \varepsilon.$$

By (2.6) and (2.8), there exists  $\delta_1 > 0$  such that

$$\mathbb{E}T_\omega^\delta(0, k_0 a n_1) - \mathbb{E}T_\omega^0(0, k_0 a n_1) < k_0 n_1 \varepsilon$$

for all  $\delta \leq \delta_1$ . So, we obtain that

$$\limsup_{\delta \rightarrow 0} \left[ \inf_{n \geq 1} \frac{\mathbb{E}T_\omega^\delta(0, k_0 a n)}{k_0 n} - \inf_{n \geq 1} \frac{\mathbb{E}T_\omega^0(0, k_0 a n)}{k_0 n} \right] \leq 2\varepsilon,$$

which implies (2.7). □

Now, we are ready to prove the first part of Theorem 1.4. Denote

$$W_\omega^\delta(n) = \{x \in \mathbb{Z}^d : T_\omega^\delta(0, x) \leq n\},$$

and let  $\hat{W}_\omega^\delta(n) = W_\omega^\delta(n) + (-1/2, 1/2]^d$ .

By a standard argument (see e.g. Alves et al. (2002); Bramson and Griffeath (1980); Durrett and Griffeath (1982)) one can show that, for any  $\varepsilon > 0$ ,

$$(1 - \varepsilon)F_\delta \subset \frac{\hat{W}_\omega^\delta(n)}{n} \subset (1 + \varepsilon)F_\delta \tag{2.9}$$

for all  $n$  large enough. In particular, since  $n^{-1}\hat{W}_\omega^\delta(n) \subset (1 + \varepsilon)F$  for all  $n$  large enough, the first claim of Theorem 1.4 follows.

In order to prove the second claim, let us define by

$$R_\omega^{x, \delta}(n) = \{y \in \mathbb{Z}^d : \text{there exist } z_0, z_1, \dots, z_n \in \mathbb{Z}^d \text{ with } z_0 = x, z_n = y \text{ such that } \omega_{z_i}(v : v_{z_{i+1}-z_i} \geq 1) > \delta, \ i = 0, \dots, n-1\}, \tag{2.10}$$

the set of sites that can be reached in *exactly*  $n$  steps (with our usual restriction on the probabilities of the steps). Clearly, if  $y \in R_\omega^{x, \delta}(n)$ , then  $\mathbf{E}_\omega \eta_n^x(y) \geq \delta^n$ . Denoting also  $\hat{R}_\omega^{x, \delta}(n) = R_\omega^{x, \delta}(n) + (-1/2, 1/2]^d$ , we intend to prove that, for any  $\varepsilon > 0$  and almost all  $\omega$

$$(1 - \varepsilon)F_\delta \subset \frac{\hat{R}_\omega^{0, \delta}(n)}{n} \subset (1 + \varepsilon)F_\delta \tag{2.11}$$

for all  $n$  large enough.

Let (recall the definition of  $\mathcal{K}$  from (2.1))

$$M_n^\delta = \{\omega : \text{for any } x \in \mathcal{K}_{L_0 n} \text{ there exists a } \delta\text{-aperiodic site } y \text{ such that } \|x - y\| \leq n^{1/2}\}.$$

Since the random environment is finitely dependent, one obtains that there are some positive constants  $\delta_0, C_1, C_2$  such that for all  $\delta \leq \delta_0$

$$\mathbb{P}[M_n^\delta] \geq 1 - C_1 n^d \exp(-C_2 n^{-d/2}). \tag{2.12}$$

By Borel-Cantelli lemma,

$$\mathbb{P}[\text{there exists } n(\omega) \text{ such that } M_n^\delta \text{ occurs for all } n \geq n(\omega)] = 1. \tag{2.13}$$

Fix any  $\varepsilon > 0$  and consider a site  $x \in (1 - \varepsilon)nF_\delta$ . As we know from (2.9), if  $n$  is large enough, then  $T_\omega^\delta(0, x) \leq (1 - \frac{\varepsilon}{2})n$  and the event  $M_n^\delta$  occurs. Now, consider two cases:

- (1)  $n - T_\omega^\delta(0, x)$  is even. Then it is trivial to obtain that  $x \in R_\omega^{0,\delta}(n)$  (one can complete the path of length  $T_\omega^\delta(0, x)$  which ends in  $x$  by  $x + e_1, x, x + e_1, x, \dots$ ).
- (2)  $n - T_\omega^\delta(0, x)$  is odd. Suppose also that  $n$  is so large that  $\max\{L_0, n^{1/2}\} < \frac{\varepsilon n}{6}$ . Since  $M_n^\delta$  occurs, there exists an aperiodic site  $y$  such that  $\|x - y\| < \frac{\varepsilon n}{6}$ . Then, to complete the path of length  $T_\omega^\delta(0, x)$  which ends in  $x$ , essentially one goes from  $x$  to  $y$  in exactly  $\|x - y\|$  steps, then jumps from  $y$  to some  $y_1$  with  $\|y - y_1\|$  even, then goes back to  $x$  (and then, if necessary, one puts  $x + e_1, x, x + e_1, x, \dots$  to the end of the path).

In both cases we obtain that  $x \in R_\omega^{0,\delta}(n)$ , and this concludes the proof of (2.11) and thus of Theorem 1.4. □

2.3. *Proof of Theorems 1.5 and 1.6.* We begin by showing that the function  $\beta$  can be defined in the following way:

**Lemma 2.4.** *For any  $a \in F^o \cap \mathbb{Q}^d$ ,  $a \neq 0$ , the following quantity  $\beta(a)$  is well-defined and is a.s. constant:*

$$\beta(a) = \lim_{n \rightarrow \infty} \frac{\ln \mathbb{E}_\omega \eta_{k_0 n}^0(k_0 n a)}{k_0 n} \quad \text{a.s.}, \tag{2.14}$$

where  $k_0$  is the smallest positive even integer number such that  $k_0 a \in 2\mathbb{Z}^d$ .

*Proof:* The expected number of particles  $\mathbb{E}_\omega \eta$  has a supermultiplicative property: for any  $x, y, z \in \mathbb{Z}^d$ ,  $n_1, n_2 \geq 0$

$$\mathbb{E}_\omega \eta_{n_1}^x(y) \mathbb{E}_\omega \eta_{n_2}^y(z) \leq \mathbb{E}_\omega \eta_{n_1+n_2}^x(z), \tag{2.15}$$

so the family of random variables

$$S_{m,n} = k_0^{-1} \ln \mathbb{E}_\omega \eta_{k_0(n-m)}^{k_0 m a}(k_0 n a)$$

is superadditive. Note, however, that the random variables of the latter family may assume the value  $-\infty$ .

Suppose first that  $\|a\| \leq 1$ . Then, from Condition UE we obtain that

$$\mathbb{E}_\omega \eta_{k_0}^0(k_0 a) \geq \varepsilon_0^{k_0},$$

and so, taking Condition D into account, the existence of the limit in (2.14) immediately follows from the Subadditive Ergodic Theorem.

However, if one wants to apply the Subadditive Ergodic Theorem to the family  $S_{m,n}$  in the case  $\|a\| > 1$ , there is the following difficulty: there may be some  $a \in F \cap \mathbb{Q}^d$ , such that with positive probability it happens that  $T_\omega^0(0, k_0na) > k_0n$ , which means that  $\mathbb{E}(-\ln \mathbf{E}_\omega \eta_{k_0n}^0(k_0na))^+ = \infty$  (even  $\mathbb{P}[(-\ln \mathbf{E}_\omega \eta_{k_0n}^0(k_0na))^+ = \infty] > 0$ ). So, for the case  $\|a\| > 1$  we need a different approach.

For the rest of the proof of Lemma 2.4 we suppose that  $\|a\| > 1$  and let  $\delta$  be such that  $a \in F_\delta^o$ . Define

$$\beta(a) = \limsup_{n \rightarrow \infty} \frac{\ln \mathbf{E}_\omega \eta_{k_0n}^0(k_0an)}{k_0n} \tag{2.16}$$

(in principle,  $\beta(a)$  could depend also on  $\omega$ , but in the next few lines we will show that it is a.s. constant). By (2.11),  $\mathbb{P}$ -a.s. there exists  $n(\omega)$  such that (recall (2.10))  $k_0an \in R_\omega^{0,\delta}(k_0n)$  for all  $n \geq n(\omega)$ . Using (2.15), we obtain that for all  $n \geq n(\omega)$

$$\ln \mathbf{E}_\omega \eta_{k_0(n+m)}^0(k_0a(n+m)) \geq \ln \mathbf{E}_\omega \eta_{k_0n}^0(k_0an) + \ln \mathbf{E}_\omega \eta_{k_0m}^{k_0an}(k_0a(n+m))$$

for all  $m$  such that  $k_0a(n+m) \in R_\omega^{k_0an,\delta}(k_0m)$ , which means that

$$\limsup_{m \rightarrow \infty} \frac{\ln \mathbf{E}_\omega \eta_{k_0m}^0(k_0am)}{k_0m} \geq \limsup_{m \rightarrow \infty} \frac{\ln \mathbf{E}_\omega \eta_{k_0m}^{k_0an}(k_0a(n+m))}{k_0m}$$

for all  $n \geq n(\omega)$ . Since the sequence

$$\left( \limsup_{m \rightarrow \infty} \frac{\ln \mathbf{E}_\omega \eta_{k_0m}^{k_0an}(k_0a(n+m))}{k_0m} \right)_{n=0,1,2,\dots}$$

is stationary ergodic, this shows that the upper limit in (2.16) is a.s. constant.

Now, our goal is to prove that

$$\liminf_{n \rightarrow \infty} \frac{\ln \mathbf{E}_\omega \eta_{k_0n}^0(k_0an)}{k_0n} \geq \beta(a). \tag{2.17}$$

Choose  $r \in \mathbb{Q} \cap (1, +\infty)$  in such a way that  $ra \in F_\delta^o$ ; let  $k_1$  be the smallest positive integer such that  $k_1r \in \mathbb{Z}$ . Fix a small  $\alpha > 0$ . By (2.11), for all  $n$  large enough we have  $k_0k_1ra \lfloor \alpha n \rfloor \in R_\omega^{0,\delta}(k_0k_1 \lfloor \alpha n \rfloor)$ . Recall that, if  $y \in R_\omega^{x,\delta}(n)$ , then  $\mathbf{E}_\omega \eta_y^x(n) \geq \delta^n$ , so

$$\mathbf{E}_\omega \eta_{k_0k_1 \lfloor \alpha n \rfloor}^0(k_0k_1ra \lfloor \alpha n \rfloor) \geq \delta^{k_0k_1 \lfloor \alpha n \rfloor}. \tag{2.18}$$

To proceed, we use the approach of Steele (1989). Fix any  $\varepsilon > 0$  and define the events

$$\begin{aligned} H^m(N) &= \{S_{m,m+k} < k(\beta(a) - \varepsilon) \text{ for all } k = 1, \dots, N\}, \\ G^m(N) &= (H^m(N))^c. \end{aligned}$$

By definition, we have that

$$\mathbb{P}[H^m(N)] \rightarrow 0 \quad \text{as } N \rightarrow \infty. \tag{2.19}$$

Now, we divide the integer interval  $[k_1r \lfloor \alpha n \rfloor, n)$  into some subintervals and some singletons using the following algorithm. Begin with  $k = k_1r \lfloor \alpha n \rfloor$ ; inductively, let  $k$  be the smallest integer not yet assigned. If the event  $G^k(N)$  occurs, then there exists  $\ell \leq N$  such that  $S_{k,k+\ell} \geq \ell(\beta(a) - \varepsilon)$ . In this case we add the interval  $[k, k + \ell)$  to our collection (and then pass to  $k' = k + \ell$ ). On the other hand, if the event  $H^k(N)$  occurs, then we declare  $k$  to be a singleton (and then pass to  $k' = k + 1$ ). As a result

of this procedure, we obtain  $u$  intervals  $[\tau_i, \tau_i + \ell_i]$ ,  $i = 1, \dots, u$ , and  $w$  singletons  $\sigma_1, \dots, \sigma_w$ . For each of the above intervals, we have  $S_{\tau_i, \tau_i + \ell_i} \geq \ell_i(\beta(a) - \varepsilon)$ , so that

$$\mathbf{E}_\omega \eta_{k_0 \ell_i}^{k_0 a \tau_i}(k_0 a(\tau_i + \ell_i)) \geq \exp(k_0 \ell_i(\beta(a) - \varepsilon)), \tag{2.20}$$

$i = 1, \dots, u$ .

Then, Condition UE implies that

$$\mathbf{E}_\omega \eta_{k_0 \|a\|}^{k_0 a m}(k_0 a(m + 1)) \geq \varepsilon_0^{k_0 \|a\|} \tag{2.21}$$

for any  $m$ . So, abbreviating  $\varphi_1(n) = \sum_{i=1}^u \ell_i$ ,  $\varphi_2(n) = w = n - k_1 r a \lfloor \alpha n \rfloor - \varphi_1(n)$ ,  $t_n = k_0 \varphi_1(n) + k_0 \|a\| \varphi_2(n)$ , we obtain from (2.15), (2.18), (2.20), and (2.21) that

$$\begin{aligned} \mathbf{E}_\omega \eta_{t_n + k_0 k_1 \lfloor \alpha n \rfloor}^0(k_0 a n) &\geq \mathbf{E}_\omega \eta_{k_0 k_1 \lfloor \alpha n \rfloor}^0(k_0 k_1 r a \lfloor \alpha n \rfloor) \prod_{i=1}^u \mathbf{E}_\omega \eta_{k_0 \ell_i}^{k_0 a \tau_i}(k_0 a(\tau_i + \ell_i)) \\ &\quad \times \prod_{j=1}^w \mathbf{E}_\omega \eta_{k_0 \|a\|}^{k_0 a \sigma_j}(k_0 a(\sigma_j + 1)) \\ &\geq \delta^{k_0 k_1 \lfloor \alpha n \rfloor} \exp(k_0 \varphi_1(n)(\beta(a) - \varepsilon)) \varepsilon_0^{k_0 \|a\| \varphi_2(n)}. \end{aligned} \tag{2.22}$$

By construction of the intervals, we have

$$\sum_{i=1}^u \ell_i \geq n - k_1 r \lfloor \alpha n \rfloor - N - \sum_{j=k_1 r \lfloor \alpha n \rfloor}^n \mathbf{1}_{H^j(N)},$$

so, by Birkhoff's theorem

$$\liminf_{n \rightarrow \infty} \frac{\varphi_1(n)}{n} \geq (1 - \mathbb{P}[H^0(N)])(1 - k_1 r \alpha); \tag{2.23}$$

then,

$$\limsup_{n \rightarrow \infty} \frac{\varphi_2(n)}{n} \leq \mathbb{P}[H^0(N)](1 - k_1 r \alpha). \tag{2.24}$$

Take  $\alpha$  small so that  $k_1 r \alpha < 1$ . Note that  $t_n = k_0(n - k_1 r \lfloor \alpha n \rfloor + (\|a\| - 1)\varphi_2(n))$ , so, by (2.24) and (2.19),

$$\limsup_{n \rightarrow \infty} \frac{t_n}{k_0 n} \leq (1 - k_1 r \alpha)(1 + (\|a\| - 1)\mathbb{P}[H^0(N)]) < 1 - k_1 \alpha \tag{2.25}$$

if  $N$  is so large that  $\mathbb{P}[H^0(N)] \leq k_1(r - 1)\alpha(1 - k_1 r \alpha)^{-1}(\|a\| - 1)^{-1}$ . Thus, using (2.22), we obtain

$$\begin{aligned} \mathbf{E}_\omega \eta_{k_0 n}^0(k_0 a n) &\geq \mathbf{E}_\omega \eta_{t_n + k_0 k_1 \lfloor \alpha n \rfloor}^0(k_0 a n) \mathbf{E}_\omega \eta_{k_0 n - t_n - k_0 k_1 \lfloor \alpha n \rfloor}^{k_0 a n}(k_0 a n) \\ &\geq \delta^{k_0 k_1 \lfloor \alpha n \rfloor} \exp(k_0 \varphi_1(n)(\beta(a) - \varepsilon)) \varepsilon_0^{k_0(\|a\| \varphi_2(n) + n - \frac{t_n}{k_0} - k_1 \lfloor \alpha n \rfloor)}. \end{aligned}$$

The inequality (2.17) now follows from (2.19), (2.23) (note also that, trivially,  $\limsup_{n \rightarrow \infty} n^{-1} \varphi_1(n) \leq 1$ ), and (2.24). Letting  $\alpha \searrow 0$ , this concludes the proof of Lemma 2.4.  $\square$

**Lemma 2.5.** *The function  $\beta(a)$  is convex downwards on  $F^\circ \cap \mathbb{Q}^d$  (and so it can be defined for all  $a \in F^\circ$  by continuity, preserving the convexity).*

*Proof:* Consider  $a, b \in F^o$  such that  $\|a - b\| \leq 1$ , and note that there exists  $\delta > 0$  such that  $a, b \in F_\delta^o$ . Now, we have to prove that for any  $s \in (0, 1) \cap \mathbb{Q}$ ,

$$\beta(sa + (1 - s)b) \leq s\beta(a) + (1 - s)\beta(b). \quad (2.26)$$

Let  $k_0 = \min\{k \in 2\mathbb{N} : ka \in 2\mathbb{Z}^d\}$ ,  $k_1 = \min\{k \in 2\mathbb{N} : kb \in 2\mathbb{Z}^d\}$ , and  $\ell = \min\{k \in \mathbb{N} : ks \in \mathbb{N}\}$ . Use the abbreviation

$$A_n^m(x) = \mathbf{1}\{k_0 k_1 \ell x n \in R_\omega^{k_0 k_1 \ell x m, \delta}(k_0 k_1 \ell(n - m))\}.$$

Note that, by (2.11), Lemma 2.4, and the bounded convergence theorem, for any  $x \in F_\delta^o$  it holds that (with  $k' = \min\{k \in 2\mathbb{N} : kx \in 2\mathbb{Z}^d\}$ ; we use the convention  $0 \times \infty = 0$ )

$$\frac{\mathbb{E}(\mathbf{1}\{k' x n \in R_\omega^{0, \delta}\} \ln \mathbf{E}_\omega \eta_{k' n}^0(k' x n))}{k' n} \rightarrow \beta(x) \quad \text{as } n \rightarrow \infty. \quad (2.27)$$

From the supermultiplicative property (2.15) we obtain

$$\begin{aligned} & \frac{\ln \mathbf{E}_\omega \eta_{k_0 k_1 \ell n}^0(k_0 k_1 \ell(sa + (1 - s)b)n)}{k_0 k_1 \ell n} \mathbf{1}_{A_{s n}^0(sa)} \mathbf{1}_{A_n^{s n}(sa + (1 - s)b)} \\ & \geq s \frac{\ln \mathbf{E}_\omega \eta_{k_0 k_1 \ell s n}^0(k_0 k_1 \ell s a n)}{k_0 k_1 \ell s n} \mathbf{1}_{A_{s n}^0(sa)} \mathbf{1}_{A_n^{s n}(sa + (1 - s)b)} \\ & \quad + (1 - s) \frac{\ln \mathbf{E}_\omega \eta_{k_0 k_1 \ell(1 - s)n}^{k_0 k_1 \ell s a n}(k_0 k_1 \ell(sa + (1 - s)b)n)}{k_0 k_1 \ell(1 - s)n} \mathbf{1}_{A_{s n}^0(sa)} \mathbf{1}_{A_n^{s n}(sa + (1 - s)b)}. \end{aligned} \quad (2.28)$$

Since

$$\begin{aligned} & \mathbf{1}_{A_n^{s n}(sa + (1 - s)b)} \mathbf{E}_\omega \eta_{k_0 k_1 \ell(1 - s)n}^{k_0 k_1 \ell s a n}(k_0 k_1 \ell(sa + (1 - s)b)n) \\ & \stackrel{\text{law}}{=} \mathbf{1}_{A_{(1 - s)n}^0((1 - s)b)} \mathbf{E}_\omega \eta_{k_0 k_1 \ell(1 - s)n}^0(k_0 k_1 \ell(1 - s)b n), \end{aligned}$$

taking expectations in (2.28) and applying (2.27), we obtain (2.26) (note also the following elementary fact: if  $\xi \leq b$  a.s., then  $\mathbb{E}\xi \mathbf{1}_A \geq \mathbb{E}\xi - b\mathbb{P}[A]$ ).  $\square$

Now, we are able to prove Theorem 1.5.

*Proof of Theorem 1.5:* Consider a closed set  $G \subset F^o$  and fix any  $\varepsilon > 0$ . There exists  $\delta > 0$  such that  $G \subset F_\delta^o$ . Clearly, for any small enough  $\varepsilon' > 0$  there exist  $a_1, \dots, a_\ell \in (\mathbb{Q}^d \cap F_\delta^o) \setminus \{0\}$  such that

$$\sup_{b \in G} \min_{i=1, \dots, \ell} \|b - (1 - \varepsilon')a_i\| < \varepsilon'/2. \quad (2.29)$$

Let  $k_i = \min\{k \in 2\mathbb{N} : ka_i \in 2\mathbb{Z}^d\}$ , and let  $m_i = \max\{m : k_i m \leq (1 - \varepsilon')n\}$ ,  $i = 1, \dots, \ell$ . Then, by Lemma 2.4,

$$\frac{\ln \mathbf{E}_\omega \eta_{k_i m_i}^0(k_i a_i m_i)}{k_i m_i} \geq \beta(a_i) - \varepsilon \quad (2.30)$$

for all  $n$  large enough,  $i = 1, \dots, \ell$ . Using (2.29), we obtain that for any  $y \in nG$  there exists  $i$  such that  $\|y - (1 - \varepsilon')a_i n\| \leq \varepsilon' n/2$ . Then, analogously to the proof of the second claim of Theorem 1.4, we can show that on the event  $M_n^{\delta_0}$

$$\mathbf{E}_\omega \eta_{n - k_i m_i}^{k_i a_i m_i}(y) \geq \delta_0 \varepsilon_0^{n - k_i m_i} \quad (2.31)$$

for all  $n$  large enough (note that  $n - k_i m_i \geq \varepsilon' n$ ). Now, from (2.15), (2.30), and (2.31) we obtain that

$$\begin{aligned} \mathbf{E}_\omega \eta_n^0(y) &\geq \mathbf{E}_\omega \eta_{k_i m_i}^0(k_i a_i m_i) \mathbf{E}_\omega \eta_{n - k_i m_i}^{k_i a_i m_i}(y) \\ &\geq \exp(k_i m_i (\beta(a_i) - \varepsilon)) \delta_0 \varepsilon_0^{n - k_i m_i} \\ &\geq \delta_0 \exp(n((1 - 2\varepsilon')(\beta(a_i) - \varepsilon) - 2\varepsilon' \ln \varepsilon_0^{-1})). \end{aligned}$$

So, from the uniform continuity of  $\beta$  in  $G$  (cf. Lemma 2.5) we obtain that

$$\liminf_{n \rightarrow \infty} \min_{x \in nG \cap \mathbb{Z}^d} (n^{-1} \ln \mathbf{E}_\omega \eta_n^0(x) - \beta(x/n)) \geq 0.$$

To complete the proof of Theorem 1.5, we have to show that

$$\limsup_{n \rightarrow \infty} \max_{x \in nG \cap \mathbb{Z}^d} (n^{-1} \ln \mathbf{E}_\omega \eta_n^0(x) - \beta(x/n)) \leq 0. \tag{2.32}$$

Again, for any small enough  $\varepsilon' > 0$  there exist  $a_1, \dots, a_\ell \in (\mathbb{Q}^d \cap F_\delta^o) \setminus \{0\}$  such that

$$\sup_{b \in G} \min_{i=1, \dots, \ell} \|b - (1 + \varepsilon') a_i\| < \varepsilon'/2. \tag{2.33}$$

Recall  $k_i = \min\{k \in 2\mathbb{N} : k a_i \in 2\mathbb{Z}^d\}$ , and let  $m'_i = \min\{m : k_i m \geq (1 + \varepsilon') n\}$ ,  $i = 1, \dots, \ell$ .

Suppose that there exists  $y \in nG$  such that

$$\frac{\ln \mathbf{E}_\omega \eta_n^0(y)}{n} \geq \beta(y/n) + 2\varepsilon.$$

By (2.33), there exists  $i$  such that  $\|y - (1 + \varepsilon') a_i n\| \leq \varepsilon' n/2$ . Then, on the one hand, Lemma 2.4 implies that

$$\mathbf{E}_\omega \eta_{k_i m'_i}^0(k_i a_i m'_i) < \exp(k_i m'_i (\beta(a_i) + \varepsilon))$$

for all  $n$  large enough, and, on the other hand,

$$\begin{aligned} \mathbf{E}_\omega \eta_{k_i m'_i}^0(k_i a_i m'_i) &\geq \mathbf{E}_\omega \eta_n^0(y) \mathbf{E}_\omega \eta_{k_i m'_i - n}^y(k_i a_i m'_i - y) \\ &\geq \exp(n(\beta(y/n) + 2\varepsilon)) \delta_0 \varepsilon_0^{k_i m'_i - n}. \end{aligned}$$

This leads to a contradiction when  $\varepsilon'$  is small enough, and thus we obtain (2.32). The proof of Theorem 1.5 is completed.  $\square$

*Proof of Theorem 1.6:* First, note that recurrence implies the existence of  $\mathbf{p}$ -recurrent seeds (cf. Lemma 3.1 of Comets and Popov (2007) and Definition 2.2 above). Such seeds give rise to a supercritical Galton-Watson process that survives with positive probability (see Comets and Popov (2007) for details) and so the expected number of the particles at the origin grows exponentially, thus showing that  $\beta(0) > 0$ .

On the other hand, if  $\beta(0) > 0$ , then Theorem 1.5 implies that, with positive  $\mathbb{P}$ -probability, there exists  $n \geq 1$  (possibly depending on  $\omega$ ) such that  $\mathbf{E}_\omega \eta_n^0(0) > 1$ . This implies the existence of a recurrent seed. Indeed, denote

$$\mathcal{B}_\varepsilon(\omega) = \{\tilde{\omega} \in \mathcal{M} : \tilde{\omega}(v) > 0 \text{ if and only if } \omega(v) > 0, |\tilde{\omega}(v) - \omega(v)| < \varepsilon\},$$

and take  $U = \mathcal{K}_{nL_0}$ . Choose a small  $\varepsilon$  in such a way that  $\mathbf{E}_{\tilde{\omega}} \eta_n^0(0) > 1$  for any  $\tilde{\omega}$  such that  $\tilde{\omega}_x \in \mathcal{B}_\varepsilon(\omega_x)$  for all  $x \in \mathcal{K}_{nL_0}$ . Then,  $(\mathcal{K}_{nL_0}, (\mathcal{B}_\varepsilon(\omega_x), x \in \mathcal{K}_{nL_0}))$  is a recurrent seed, and so the branching random walk is recurrent.  $\square$



2.4. *Proof of Theorem 1.7.* Fix  $\varepsilon > 0$  and consider any  $y \in nG$ . By Theorem 1.5, there exists  $n(\omega, G)$  (which does not depend on  $y$ ) such that  $\mathbf{E}_\omega \eta_n^0(y) \leq \exp((\beta(y/n) + \varepsilon)n)$  for all  $n \geq n(\omega, G)$ . We write

$$\mathbf{P}_\omega[\eta_n^0(y) \geq \exp((\beta(y/n) + 2\varepsilon)n)] \leq \frac{\mathbf{E}_\omega \eta_n^0(y)}{\exp((\beta(y/n) + 2\varepsilon)n)} \leq e^{-\varepsilon n},$$

so, by Borel-Cantelli lemma,

$$\liminf_{n \rightarrow \infty} \max_{x \in nG \cap \mathbb{Z}^d} (n^{-1} \ln \eta_n^0(x) - \beta(x/n)) \leq 0 \quad \mathbf{P}_\omega\text{-a.s.} \quad (2.34)$$

Now, we have to show that

$$\limsup_{n \rightarrow \infty} \min_{x \in nG \cap \mathbb{Z}^d} (n^{-1} \ln \eta_n^0(x) - \beta(x/n)) \geq 0 \quad \mathbf{P}_\omega\text{-a.s.} \quad (2.35)$$

In order to prove (2.35), let us first prove that, for any  $a \in \mathbb{Q}^d \cap F^o$

$$\liminf_{n \rightarrow \infty} \frac{\ln \eta_{k_0 n}^0(k_0 a n)}{k_0 n} \geq \beta(a) \quad \mathbf{P}_\omega\text{-a.s.}, \quad (2.36)$$

where  $k_0 = \min\{k \in 2\mathbb{N} : ka \in 2\mathbb{Z}^d\}$ .

**Step 1:** First of all, we establish that, for any  $\varepsilon > 0$

$$\mathbf{P}_\omega \left[ \liminf_{n \rightarrow \infty} \frac{\ln \eta_{k_0 n}^0(k_0 a n)}{k_0 n} \geq \beta(a) - \varepsilon \right] > 0 \quad \text{for } \mathbb{P}\text{-almost all } \omega. \quad (2.37)$$

Choose  $\delta > 0$  such that  $a \in F_\delta^o$ , then choose a positive  $h \in \mathbb{Q}$  in such a way that  $a(1-h)^{-1} \in F_\delta^o$ , then let  $k_1 = \min\{k \in 2\mathbb{N} : ka \in 2\mathbb{Z}^d, kh \in 2\mathbb{Z}\}$ . Abbreviate

$$g_n = \mathbb{P}[k_1 a n \in R_\omega^{0,\delta}(k_1(1-h)n)];$$

recall that, by (2.11),  $g_n \rightarrow 1$  as  $n \rightarrow \infty$ . By virtue of (2.27),

$$\frac{\mathbb{E}(\mathbf{1}\{k_1 a n \in R_\omega^{0,\delta}(k_1(1-h)n)\} \ln \mathbf{E}_\omega \eta_{k_1(1-h)n}^0(k_1 a n))}{k_1(1-h)n} \rightarrow \beta((1-h)^{-1}a),$$

so one can choose  $n_1$  such that

$$\frac{\mathbb{E}(\mathbf{1}\{k_1 a n_1 \in R_\omega^{0,\delta}(k_1(1-h)n_1)\} \ln \mathbf{E}_\omega \eta_{k_1(1-h)n_1}^0(k_1 a n_1))}{k_1(1-h)n_1} \geq \beta((1-h)^{-1}a) - \varepsilon, \quad (2.38)$$

and also

$$1 - 2h < (1-h)g_{n_1} + \|a\|(1-g_{n_1}) < 1, \quad (2.39)$$

$$\begin{aligned} (\beta((1-h)^{-1}a) - 2\varepsilon)(1-h) &< (\beta((1-h)^{-1}a) - \varepsilon)(1-h)g_{n_1} \\ &\quad - \|a\| \ln \varepsilon_0^{-1}(1-g_{n_1}). \end{aligned} \quad (2.40)$$

Now, we construct a branching process in random environment  $(\Upsilon_\ell, \ell=0, 1, 2, \dots)$  in the following way. Here,  $\Upsilon_\ell$  stands for the size of  $\ell$ th generation of this process. With respect to the original process, the particles of  $\ell$ th generation are in  $k_1 a \ell n_1$  at time  $t_\ell$  defined below (note that it means that  $\Upsilon_\ell \leq \eta_{k_1 a \ell n_1}^0$ , but the equality should not necessarily hold true, there may be also some particles in  $k_1 a \ell n_1$  at time  $t_\ell$  which do not belong to this branching process in random environment). Specifically, the initial particle is considered the particle of 0th generation, and we set  $\Upsilon_0 = 1, t_0 = 0$ . Inductively, consider the  $\Upsilon_{\ell-1}$  particles of  $(\ell-1)$ th generation,

situated in  $k_1 a(\ell - 1)n_1$  at the moment  $t_{\ell-1}$ . Then, the particles of  $\ell$ th generation are their descendants which are in  $k_1 a \ell n_1$  at time  $t_\ell$ , where

$$t_\ell = \begin{cases} t_{\ell-1} + k_1(1-h)n_1, & \text{on } \{k_1 a \ell n_1 \in R_\omega^{k_1 a(\ell-1)n_1, \delta}(k_1(1-h)n_1)\} \\ t_{\ell-1} + k_1 \|a\| n_1, & \text{on } \{k_1 a \ell n_1 \notin R_\omega^{k_1 a(\ell-1)n_1, \delta}(k_1(1-h)n_1)\}. \end{cases}$$

By Birkhoff's theorem,

$$\lim_{m \rightarrow \infty} \frac{t_m}{m} = k_1 n_1 ((1-h)g_{n_1} + \|a\|(1-g_{n_1})),$$

and, by Condition UE and (2.40),

$$\begin{aligned} \mathbb{E} \ln \mathbf{E}_\omega \Upsilon_1 &\geq (\beta((1-h)^{-1}a) - \varepsilon)k_1(1-h)n_1 g_{n_1} - k_1 \|a\| n_1 \ln \varepsilon_0^{-1}(1-g_{n_1}) \\ &\geq (\beta((1-h)^{-1}a) - 2\varepsilon)k_1(1-h)n_1. \end{aligned} \quad (2.41)$$

Assume that  $\varepsilon$  is so small that  $\beta((1-h)^{-1}a) > 2\varepsilon$ . Since (by Condition UE and using the fact that  $a(1-h)^{-1} \in F_\omega^g$ )

$$\mathbb{P}_\omega[\Upsilon_1 \geq 1] \geq \min\{\varepsilon_0^{k_1 \|a\| n_1}, \delta^{k_1(1-h)n_1}\},$$

one can use e.g. Theorem 1 of Athreya and Karlin (1971), or Theorem 5.5 and Proposition 6.2 of Tanny (1977) to obtain that

$$\mathbb{P}_\omega[\text{the process } \Upsilon \text{ survives}] > 0 \quad \mathbb{P}\text{-a.s.}, \quad (2.42)$$

and

$$\mathbb{P}_\omega[\liminf_{m \rightarrow \infty} m^{-1} \ln \Upsilon_m \geq (\beta((1-h)^{-1}a) - 2\varepsilon)k_1(1-h)n_1 \mid \Upsilon \text{ survives}] = 1. \quad (2.43)$$

On the event  $\{\liminf_{m \rightarrow \infty} m^{-1} \ln \Upsilon_m \geq (\beta((1-h)^{-1}a) - 2\varepsilon)k_1(1-h)n_1\}$  one can choose  $m_0$  (depending on  $\omega$ ) such that

$$\frac{\ln \Upsilon_m}{m} \geq (\beta((1-h)^{-1}a) - 3\varepsilon)k_1(1-h)n_1$$

and

$$(1-2h)k_1 n_1 \leq \frac{t_m}{m} \leq k_1 n_1$$

for all  $m \geq m_0$ . Then, at the moment  $t_m$  we have at least

$$\Upsilon_m \geq \exp(mk_1 n_1(1-h)(\beta((1-h)^{-1}a) - 3\varepsilon))$$

particles in  $k_1 a n_1 m$ . By Condition UE, each of those particles has a descendant in  $k_1 a n_1 m$  at time  $k_1 n_1 m$  with probability at least  $\varepsilon_0^{2hk_1 n_1 m}$ . So, using the large deviation bound for the binomial distribution (cf. e.g. formula (34) of Comets and Popov (2007)), we obtain that for some positive  $C_1, C_2$

$$\begin{aligned} \mathbb{P}_\omega[\eta_{k_1 n_1 m}^0(k_1 a n_1 m) \geq \exp(mk_1 n_1((1-h)(\beta((1-h)^{-1}a) - 3\varepsilon) - 2h \ln \varepsilon_0^{-1}))] \\ \geq 1 - \exp(-C_1 e^{C_2 m}). \end{aligned}$$

Using Condition UE again, we obtain (2.37).

**Step 2:** Now, let us show that (2.37) implies (2.36). This is easy in the case when the branching random walk is recurrent. Indeed, in this case it can be shown that a.s. the origin will be visited by infinitely many ‘‘free’’ particles (i.e., none of them is a descendant of another; see Comets and Popov (2007) for more details). Each of those particles gives rise to a copy of the branching process in random environment constructed above (they use the same environment, but are conditionally independent); so, with probability 1 at least one of them survives, and from this

we obtain (2.36) in the recurrent case. However, this argument does not work in the case when the branching random walk is transient, so we present a general argument that works in both cases.

Abbreviate  $\hat{u} = \max\{1 - h, \|a\|\}$ . Let

$$S_x = \{y \in \mathbb{Z}^d : \text{there is } \ell \in \mathbb{Z}_+ \text{ such that } \|x + \ell k_1 a n_1 - y\| \leq L_0 k_1 \hat{u} n_1 + \varrho\}.$$

The key observation is that the branching process  $\Upsilon$  constructed above depends only on the environment inside  $S_0$ . In particular the probability in (2.42) only depends on  $\omega_x, x \in S_0$ . Suppose that  $\Upsilon_m = 0$  for some  $m$ ; this means that up to (“real”) time  $k_1 \hat{u} n_1 m$  the branching process in random environment became extinct.

Then, the idea is the following: with positive probability it happens that a particle goes outside the already explored part of  $\omega$  “without revealing more environment”, and we can construct a new branching process in random environment, independent of the previous one.

At the moment  $k_1 \hat{u} n_1 m$  (when we know that the “initial” branching process  $\Upsilon$  in random environment became extinct), let us remove all particles except one from the process  $\eta$  (for definiteness, choose the remaining particle uniformly among the particles that are present at time  $k_1 \hat{u} n_1 m$ ). Let  $z$  be the “initial” (i.e., at time  $k_1 \hat{u} n_1 m$ ) position of this particle, note that  $\|z\| \leq L_0 k_1 \hat{u} n_1 m$ . We let this particle perform the uniform induced random walk  $\xi^z$  (i.e., immediately removing from the process other particles that may eventually appear) until some random moment  $\tau$  defined below. Let

$$\Gamma(\ell) = \{x \in \mathbb{Z}^d : \text{there exists } y \in \mathbb{Z}^d \text{ such that } y \in S_x \text{ and} \\ \text{either } \|y\| \leq L_0 k_1 \hat{u} n_1 m \text{ or } y \in \{\xi_0^z, \dots, \xi_\ell^z\}\}$$

be the set of sites from where the construction analogous to the construction of the above branching process  $\Upsilon$  may depend on already revealed pieces of the environment.

Recall the notation  $Z_t$  from Section 2.1. We define

$$\tau = \min\{s \in \mathbb{N} : \text{there exists } s' < s \\ \text{such that } Z_{s'+1} = \dots = Z_s = 1 \text{ and } \xi_s^z \notin \Gamma(s')\},$$

and also (see Figure 2.1)

$$\tilde{\Gamma}(\ell) = \{y \in \Gamma(\ell) : \text{dist}(\{y\}, \mathbb{Z}^d \setminus \Gamma(\ell)) > L_0(k_1 \hat{u} n_1 + 2) + \varrho\}.$$

Clearly, if  $\xi_\ell^z \in \tilde{\Gamma}(\ell)$ , then  $\Gamma(\ell + 1) = \Gamma(\ell)$ . From Condition UE it follows that a.s. there exists an infinite sequence  $(\tau'_k, k = 1, 2, 3, \dots)$  such that  $\xi_{\tau'_k}^z \in \Gamma(\tau'_k) \setminus \tilde{\Gamma}(\tau'_k)$  for all  $k$ . Indeed, if  $\hat{a} \in \mathbb{R}^d \setminus \{0\}$  is such that  $\hat{a} \cdot a = 0$ , then the fact that  $|(\xi_{t_1}^z - \xi_{t_2}^z) \cdot \hat{a}|$  is large enough guarantees that there is  $k$  such that  $\tau'_k \in [t_1, t_2]$ . Since from any  $u \in \Gamma(\ell) \setminus \tilde{\Gamma}(\ell)$  the particle can perform any given  $L_0(k_1 \hat{u} n_1 + 2) + \varrho$  unit steps with  $Z$ -value 1 with uniformly positive probability (and so it can go out of  $\Gamma(\ell)$  with at least that probability without revealing more environment), this shows that  $\tau < \infty$  a.s.

Now, at time  $k_1 \hat{u} n_1 m + \tau$  we can start an independent copy  $\Upsilon'$  of the branching process in random environment  $\Upsilon$  constructed above. If it happens that  $\Upsilon'$  dies out as well, repeating this construction one can start another independent copy  $\Upsilon''$ ,

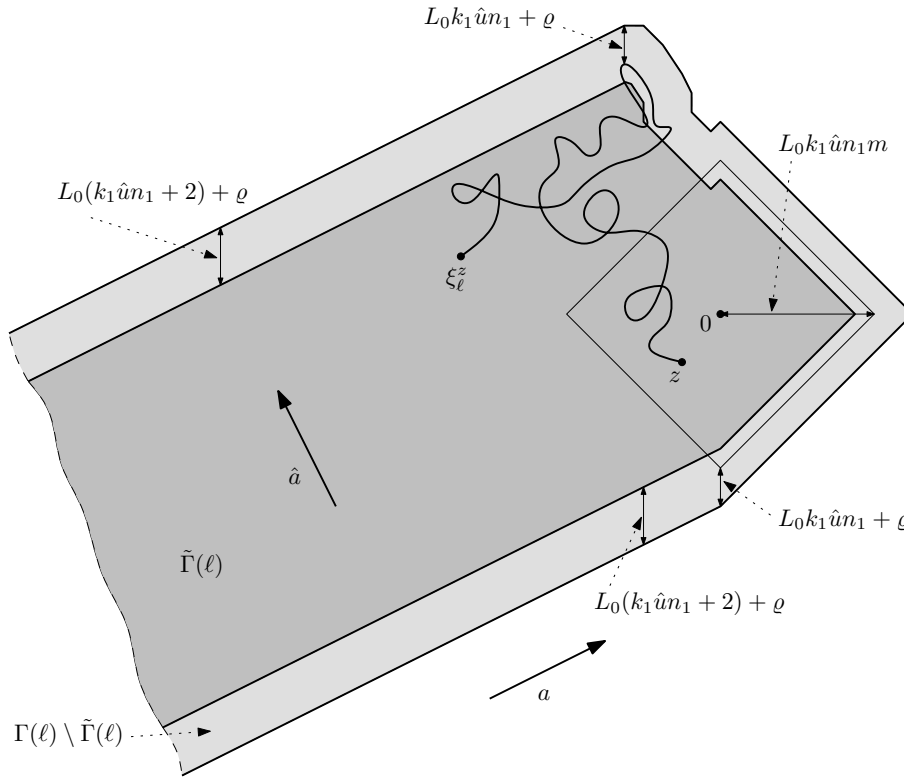

FIGURE 2.1. On the definition of the sets  $\Gamma(\ell)$  and  $\tilde{\Gamma}(\ell)$  (recall that  $\|\cdot\|$  is the  $\mathcal{L}_1$ -norm)

and so on. Eventually, one of those branching processes in random environment will survive, and so (2.36) follows from (2.43).

Now, let us prove (2.35). We use the same method as in the proof of the first part of Theorem 1.5. Namely, suppose that  $\delta > 0$  is such that  $G \subset F_\delta^o$ . For any small enough  $\varepsilon' > 0$  there exist  $a_1, \dots, a_\ell \in (\mathbb{Q}^d \cap F_\delta^o) \setminus \{0\}$  such that (2.29) holds. Let  $k_i = \min\{k \in 2\mathbb{N} : ka_i \in 2\mathbb{Z}^d\}$ , and let  $m_i = \max\{m : k_i m \leq (1 - \varepsilon'n)\}$ ,  $i = 1, \dots, \ell$ . By (2.36), provided that  $\varepsilon, n_1, h$  are chosen in such a way that

$$(1 - h)(\beta((1 - h)^{-1}a_i) - 3\varepsilon) - 2h \ln \varepsilon_0^{-1} \geq \beta(a_i) - \varepsilon''$$

we have

$$\frac{\ln \eta_{k_i m_i}^0(k_i a_i m_i)}{k_i m_i} \geq \beta(a_i) - \varepsilon'' \tag{2.44}$$

for all  $n$  large enough,  $i = 1, \dots, \ell$ . Using (2.29), we obtain that for any  $y \in nG$  there exists  $i$  such that  $\|y - (1 - \varepsilon')a_i n\| \leq \varepsilon'n/2$ . Then, we can show that on the event  $M_n^{\delta_0}$

$$\mathbb{P}_\omega[\eta_{n-k_i m_i}^{k_i a_i m_i}(y) \geq 1] \geq \delta_0 \varepsilon_0^{n-k_i m_i}. \tag{2.45}$$

So, since the particles that are in  $k_i a_i m_i$  at time  $k_i m_i$  act independently, again using a large deviation bound for the binomial distribution together with (2.44)

and (2.45), we obtain that for some positive constants  $C_3, C_4$

$$P_\omega[\eta_n^0(y) \geq \exp(k_i m_i(\beta(a_i) - 2\varepsilon))] \geq 1 - \exp(-C_3 e^{C_4 n}),$$

and this proves (2.35). Theorem 1.7 now follows from (2.34) and (2.35).  $\square$

2.5. *Exponential growth of the total number of particles and proof of Theorem 1.9.*

First, we prove the property (1.7). For the case of recurrent branching random walk, (1.7) immediately follows from Theorem 1.6, so we only need to consider the case of transient branching random walk. Without restriction of generality, one can assume that any particle can generate at most two particles at the next moment, and that there is  $h > 0$  such that the probability of generating two offspring is (depending on the location) 0 or  $h$ , i.e.,

$$P[\omega_0(|v| \leq 2) = 1] = 1, \quad P[\omega_0(|v| = 2) \in \{0, h\}] = 1. \tag{2.46}$$

This is no restriction since it can be easily shown that any branching random walk in random environment (satisfying Condition B) dominates some branching random walk in random environment satisfying (2.46). Also, it is clear that the latter branching random walk in random environment can be defined in such a way that Condition UE still holds (possibly with another constant; however, to keep the notations simple, we will assume in our argument that Condition UE holds with  $\varepsilon_0$ ).

In the situation (2.46), if  $\omega_x(|v| = 2) = h$ , we say that  $x$  is a branching site, in the case when  $\omega_x(|v| = 2) = 0$ , we say that  $x$  is a non-branching site.

Then, we can make a further simplifying assumption: we suppose that *immediate* descendants of a particle jump independently (so that we are in the situation considered e.g. in Comets et al. (1998); Machado and Popov (2000, 2003)), which means that, for a particle in  $x$ , we first decide if the particles generate 1 or 2 offspring, and then each of these offspring jump independently with probabilities  $(P_\omega[\xi_1^x = y], y \in x + \mathfrak{A})$ . Here,  $\xi^x$  is the uniform induced random walk starting from  $x$ . The reason why we can make this assumption without loss of generality is that the two branching random walks are in some sense equivalent, as mentioned in Remark 1.8.

Denote by

$$\psi_\omega(x) = P_\omega[\eta_n^x(x) = 0 \text{ for all } n \geq 1]$$

the probability that none of the descendants of a particle in  $x$  ever comes back. In the next lemma we prove that  $\psi_\omega(x)$  is uniformly positive.

**Lemma 2.6.** *There exists  $\theta > 0$ , depending only on  $h$  and  $\varepsilon_0$ , such that, for any transient branching random walk satisfying (2.46) and with independent immediate descendants, we have  $\psi_\omega(x) > \theta$ , for all  $x \in \mathbb{Z}^d$  and for  $\mathbb{P}$ -almost all  $\omega$ .*

*Proof of Lemma 2.6:* By stationarity, it is enough to prove that  $P[\psi_\omega(0) > \theta] = 1$ . We argue by contradiction. The idea is that, when  $\psi_\omega(0)$  is small enough, the branching random walk should be recurrent. We split the space of environments in three parts, and consider three cases accordingly.

Case 1. Suppose that  $\omega_0(|v| = 2) = h$ , i.e., 0 is a branching site. Abbreviating  $b := P_\omega[\eta_n^0(0) = 0 \text{ for all } n \geq 1 \mid \mathcal{Z}_1^0 = 1]$ , we have  $\psi_\omega(0) = (1 - h)b + hb^2$ , so

$$P_\omega[\eta_n^0(0) = 0 \text{ for all } n \geq 1 \mid \mathcal{Z}_1^0 = 1] = \frac{-(1-h) + \sqrt{(1-h)^2 + 4h\psi_\omega(0)}}{2h}.$$

Thus,  $\mathbb{P}_\omega[\eta_n^0(0) = 0 \text{ for all } n \geq 1 \mid \mathcal{Z}_1^0 = 1]$  can be made arbitrarily close to 0 by making  $\psi_\omega(0)$  small. Now, if

$$\mathbb{P}_\omega[\eta_n^0(0) = 0 \text{ for all } n \geq 1 \mid \mathcal{Z}_1^0 = 1] < \frac{h}{1+h},$$

then, as in the proof of Theorem 1.6, it is straightforward to show that there exists a recurrent seed and so the branching random walk is recurrent.

Case 2. We suppose that  $\omega_0(|v| = 2) = 0$ , but there is a branching site in  $\mathcal{K}_{\varrho-1} \setminus \{0\}$ . In this case we can choose a branching site there which is closest to the origin, so that it is accessible from the origin by a path of non-branching sites. This means that there exist  $k \leq \varrho - 1$ ,  $0 = x_0, x_1, \dots, x_k$  such that  $\|x_{i+1} - x_i\| = 1$ ,  $i = 0, \dots, k$ ,  $x_1, \dots, x_{k-1}$  are non-branching, and  $x_k$  is a branching site (and we have also  $\|x_k\| = k$ ).

Then, again we obtain that if  $\psi_\omega(0)$  is too small, then the branching random walk should be recurrent. For this, proceed as follows. First, define

$$\tau_1 = \min\{n \geq 1 : \eta_n^0(0) \geq 1\},$$

so that  $\mathbb{P}_\omega[\tau_1 < \infty] = 1 - \psi_\omega(0)$ . At the moment  $\tau_1$  (provided  $\tau_1 < \infty$ ), consider one of the particles which are in 0 and let

$$\tau_2 = \min\{n \geq \tau_1 + 1 : \text{at least one of the descendants of that particle is in 0 at time } n\},$$

then, repeat this procedure to define  $\tau_3$  on  $\{\tau_2 < \infty\}$ ,  $\tau_4$  on  $\{\tau_3 < \infty\}$ , and so on. Clearly,  $\mathbb{P}_\omega[\tau_m < \infty] = (1 - \psi_\omega(0))^m$ .

Being  $\xi^0$  the uniform induced random walk starting from 0, define the event

$$A = \{\xi_i^0 = x_i, i = 1, \dots, k, \xi_i^0 = x_{2k-i}, i = k + 1, \dots, 2k, \mathcal{Z}_{k+1}^0 = 2\},$$

i.e., the initial particle goes straight to  $x_k$ , branches there, and then the “first” descendant goes straight back to the origin (note that we do not assume anything about the second descendant). Clearly, we have

$$\mathbb{P}_\omega[A \mid \tau_1 < \infty] \geq \frac{h\varepsilon_0^{2k}}{1 - \psi_\omega(0)} \geq h\varepsilon_0^{2(\varrho-1)}.$$

On the event  $A$ , the second particle (generated in  $x_k$ ) goes to 0 with probability at least  $\varepsilon_0^{\varrho-1}$ . Take  $m$  such that  $m h \varepsilon_0^{3(\varrho-1)} > 1$ : if  $\psi_\omega(0)$  is small enough, then  $(1 - \psi_\omega(0))^m m h \varepsilon_0^{3(\varrho-1)} > 1$ . Then we obtain that there exists large enough  $T$  (which actually depends on  $\omega$ ) such that up to time  $T$  the mean number of “free” particles that visit the origin is greater than 1. (Recall that, by “free” particles we mean that none of them is the descendant of another one, see Definition 2.2.) As above, this implies the existence of recurrent seeds and so the branching random walk is recurrent.

Case 3. Suppose that  $\omega_x(|v| = 2) = 0$  for all  $x \in \mathcal{K}_{\varrho-1}$ , so that there are no branching sites in  $\mathcal{K}_{\varrho-1}$ . Let

$$\partial_\varepsilon \mathcal{K}_{\varrho-1} = \{x \in \mathcal{K}_{\varrho-1}^c : \text{dist}(\{x\}, \mathcal{K}_{\varrho-1}) \leq L_0\}$$

be the annulus (or extended external boundary) of  $\mathcal{K}_{\varrho-1}$ . Denote by

$$g_\omega(x, B) = \mathbb{P}_\omega\left[\text{there exists } n \geq 0 \text{ such that } \sum_{y \in B} \eta_n^x(y) \geq 1\right]$$

the probability of ever having particles in  $B \subset \mathbb{Z}^d$  for the process starting from  $x$ . For any  $x \in \partial_e \mathcal{K}_{\varrho-1}$ , we see from Condition UE that  $\psi_\omega(0) > \varepsilon_0^{\varrho+L_0} (1-h)^{L_0} (1-g_\omega(x, \partial_e \mathcal{K}_{\varrho-1}))$ , so

$$\inf_{x \in \partial_e \mathcal{K}_{\varrho-1}} g_\omega(x, \partial_e \mathcal{K}_{\varrho-1}) > 1 - \varepsilon_0^{-(\varrho+L_0)} (1-h)^{-L_0} \psi_\omega(0). \tag{2.47}$$

At this point, the important observation is that, for any  $x \in \partial_e \mathcal{K}_{\varrho-1}$ , the quantity  $g_\omega(x, \partial_e \mathcal{K}_{\varrho-1})$  is a function of the environment outside  $\mathcal{K}_{\varrho-1}$ , and so it is independent of  $\omega_0$  by Condition I. So, supposing that  $\psi_\omega(0)$  is small enough, one can construct a recurrent seed as follows. Define

$$g_\omega^{(k)}(x, B) = \mathbb{P}_\omega \left[ \text{there exists } 0 \leq n \leq k \text{ such that } \sum_{y \in B} \eta_n^x(y) \geq 1 \right],$$

and note that  $g_\omega^{(k)}(x, B) \rightarrow g_\omega(x, B)$  as  $k \rightarrow \infty$ . Then, suppose that  $\psi_\omega(0) < \tilde{\delta}$ , where (a small number)  $\tilde{\delta}$  is such that

$$\frac{\varepsilon_0^{\varrho-1}}{\varepsilon_0^{\varrho-1} + \varepsilon_0^{-(\varrho+L_0)} (1-h)^{-L_0} \tilde{\delta}} > (1+h)^{-1}. \tag{2.48}$$

Choose first large enough  $k_0$  and then small enough  $\varepsilon$  in such a way that

$$\inf_{x \in \partial_e \mathcal{K}_{\varrho-1}} g_{\tilde{\omega}}^{(k_0)}(x, \partial_e \mathcal{K}_{\varrho-1}) > 1 - \varepsilon_0^{-(\varrho+L_0)} (1-h)^{-L_0} \tilde{\delta} \tag{2.49}$$

for all  $\tilde{\omega}$  such that  $\tilde{\omega}_x \in \mathcal{B}_\varepsilon(\omega_x)$  for all  $x \in \mathcal{K}_{\varrho+k_0 L_0} \setminus \mathcal{K}_{\varrho-1}$  (here,  $\mathcal{B}_\varepsilon(\cdot)$  denotes the ball of radius  $\varepsilon$  in  $\mathcal{M}$  with respect to any fixed metrics). By the contradiction assumption and by (2.47), the set of such  $\tilde{\omega}$ 's has positive  $\mathbb{P}$ -probability.

Then, the idea is the following: put a branching site at the origin and suppose that in a sufficiently large region around 0 (excluding  $\mathcal{K}_{\varrho-1}$ ) the environment is ‘‘close’’ to the environment above. More precisely, we consider the  $(U, \mathcal{H})$ -seed with  $U = \mathcal{K}_{\varrho+k_0 L_0}$  and

$$\mathcal{H}_x = \begin{cases} \{\omega \in \mathcal{M} : \omega(|v|=2) = h\}, & \text{for } x = 0, \\ \mathcal{M}, & \text{for } x \in \mathcal{K}_{\varrho-1} \setminus \{0\}, \\ \mathcal{B}_\varepsilon(\omega_x), & \text{for } x \in \mathcal{K}_{\varrho+k_0 L_0} \setminus \mathcal{K}_{\varrho-1}. \end{cases}$$

Condition I implies that  $\mathbb{P}[\tilde{\omega} : \tilde{\omega}_x \in \mathcal{H}_x \text{ for all } x \in U] > 0$ .

Now, from each site in  $\mathcal{K}_{\varrho-1}$ , the uniform induced random walk goes to 0 without leaving  $\mathcal{K}_{\varrho-1}$  with probability at least  $\varepsilon_0^{\varrho-1}$ , and any particle in  $\partial_e \mathcal{K}_{\varrho-1}$  sends at least one descendant to  $\partial_e \mathcal{K}_{\varrho-1}$  at least with probability given by (2.49). Suppose without restriction of generality that  $\varrho - 1 \geq L_0$ . Then, the probability that any particle starting from  $\mathfrak{A}$  sends at least one descendant to 0 is at least<sup>1</sup>

$$\frac{\varepsilon_0^{\varrho-1}}{\varepsilon_0^{\varrho-1} + \varepsilon_0^{-(\varrho+L_0)} (1-h)^{-L_0} \tilde{\delta}},$$

which is greater than  $(1+h)^{-1}$  by (2.48). So, we obtain a recurrent seed.

This concludes the proof of Lemma 2.6. □

---

<sup>1</sup>Compare with the following situation. There are two coins, for the coin 1 the probability of head is  $p$ , for the coin 2 the probability of head is  $q$ . We flip the coins in an alternate fashion, i.e., 1,2,1,2,1,2,... Then, the probability that the first head comes from the coin 1 is equal to  $\frac{p}{p+q-pq} > \frac{p}{p+q}$ .

We continue the proof of Theorem 1.9. Let  $U_n = \{\xi_0^0, \xi_1^0, \dots, \xi_n^0\}$  be the range of the uniform induced random walk up to time  $n$ . We now prove that, due to Lemma 2.6,  $|U_n|$  is of order  $n$  with at least constant probability. Let

$$N(x, y) = \sum_{i=1}^{\infty} \mathbf{1}\{\xi_i^x = y\}$$

be the number of times that the uniform induced random walk starting from  $x$  visits  $y$ . Using Lemma 2.6, we obtain that  $\mathbf{E}_\omega N(x, x) \leq \theta^{-1}$  for all  $x \in \mathbb{Z}^d$  and for  $\mathbb{P}$ -almost all  $\omega$ . On the other hand

$$n \leq \sum_{x \in U_n} N(0, x),$$

so, taking expectation,

$$\begin{aligned} n &\leq \sum_{x \in \mathbb{Z}^d} \mathbf{E}_\omega(\mathbf{1}\{x \in U_n\}N(0, x)) \\ &= \sum_{x \in \mathbb{Z}^d} \mathbf{E}_\omega(\mathbf{1}\{x \in U_n\}N(0, x) \mid x \in U_n)\mathbb{P}_\omega[x \in U_n] \\ &\leq (1 + \theta^{-1})\mathbf{E}_\omega|U_n|. \end{aligned}$$

Since trivially  $|U_n| \leq n$ , using the fact that for any random variable  $X$  with  $0 \leq X \leq a$  a.s. and  $\mathbf{E}_\omega X \geq b$  it is true that  $\mathbb{P}_\omega[X \geq b/2] \geq b/(2a)$ , we obtain that, for  $\mathbb{P}$ -almost all  $\omega$ ,

$$\mathbb{P}_\omega[|U_n| \geq (1 + \theta^{-1})^{-1}n/2] \geq (1 + \theta^{-1})^{-1}/2. \tag{2.50}$$

Consider the evolution of the branching random walk up to time  $n$ , and let us enumerate the  $\mathcal{Z}_n^0$  particles that are present at time  $n$  in random order (i.e., select one particle at random and attach the label “1” to it, then select one of the unlabelled particles and put the label “2” to it, and so on). We define  $\text{br}(i, n)$  to be the number of bifurcations on the path from the root to the particle (of the  $n$ th generation) labelled  $i$  on the genealogical tree of the branching random walk (see Figure 2.2). Let  $\zeta_n$  be the label assigned to the particle corresponding to the uniform induced random walk at time  $n$ ; clearly, given the realisation of the genealogical tree,

$$\{\zeta_n = i\} \text{ has probability } 2^{-\text{br}(i, n)}. \tag{2.51}$$

Let us prove now that, on the event that the range of the uniform induced random walk is linear in  $n$ , with large probability  $\text{br}(\zeta_n, n)$  will be linear as well. To this end, we construct a set  $\Phi \subset \mathbb{Z}_+$  in the following way: first, we have  $0 \in \Phi$ . Inductively, suppose that the set  $\Phi \cap \{0, \dots, k-1\}$  was already constructed. Then,  $k \in \Phi$  if and only if the following holds:

- there exists  $y \in \mathbb{Z}^d$  such that  $\|\xi_k^0 - y\| = \varrho$ , and
- $\|\xi_m^0 - y\| \geq \varrho$  for all  $m \leq k$ .

Define the cubes

$$\hat{\mathcal{K}}_m = \{x \in \mathbb{Z}^d : \max(|x^{(1)}|, \dots, |x^{(d)}|) \leq m\},$$

note that

$$\mathbb{Z}^d = \bigcup_{z \in \mathbb{Z}^d} ((2\varrho + 2L_0 + 1)z + \hat{\mathcal{K}}_{\varrho+L_0}).$$



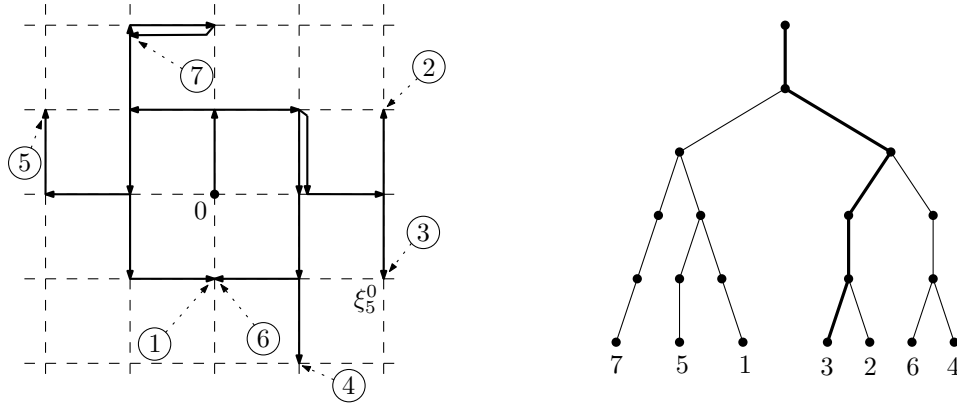

FIGURE 2.2. A realisation of the branching random walk (together with the uniform induced random walk) up to time  $n = 5$ , and the corresponding genealogical tree. We have  $\zeta_5 = 3$ ,  $\text{br}(i, 5) = 3$  for  $i = 1, \dots, 6$ ,  $\text{br}(7, 5) = 2$ .

Let  $t_0 = 0$ ,  $z_0 = 0$ . Inductively, define for  $i \geq 1$

$$t_i = \min \left\{ t : \xi_t^0 \notin \bigcup_{j=0}^{i-1} ((2\varrho + 2L_0 + 1)z_j + \hat{\mathcal{K}}_{\varrho+L_0}) \right\},$$

and  $z_i$  is such that  $\xi_{t_i}^0 \in (2\varrho + 2L_0 + 1)z_i + \hat{\mathcal{K}}_{\varrho+L_0}$ . Observe that, for any  $y \in \mathbb{Z}^d$  such that  $\text{dist}(\{y\}, \mathbb{Z}^d \setminus ((2\varrho + 2L_0 + 1)z_i + \hat{\mathcal{K}}_{\varrho+L_0})) \leq L_0$  we have

$$(y + (\mathcal{K}_\varrho \setminus \mathcal{K}_{\varrho-1})) \setminus \left( \bigcup_{x \notin (2\varrho+2L_0+1)z_i + \hat{\mathcal{K}}_{\varrho+L_0}} (x + \mathcal{K}_{\varrho-1}) \right) \neq \emptyset,$$

so  $t_i \in \Phi$  for all  $i \geq 0$ . Since  $|\hat{\mathcal{K}}_{\varrho+L_0}| = (2\varrho + 2L_0 + 1)^d$ , we have

$$|\Phi \cap \{0, \dots, n\}| \geq (2\varrho + 2L_0 + 1)^{-d} |U_n|. \tag{2.52}$$

Let  $\mathcal{F}_m$  be the sigma-algebra generated by  $(\xi_k^0, \text{br}(\zeta_k, k), k \leq m)$ . By definition of the set  $\Phi$ ,

$$\mathbf{P}[\text{br}(\zeta_{m+\varrho}, m + \varrho) \geq \text{br}(\zeta_m, m) + 1 \mid \mathcal{F}_m] \geq h\varepsilon_0^{\varrho} \mathbf{P}[\omega_0(|v| = 2) = h]. \tag{2.53}$$

Write  $\Phi = \{0 = \varphi_0, \varphi_1, \varphi_2, \dots\}$ , where  $\varphi_{i+1} \geq \varphi_i$  for all  $i \geq 0$ . Abbreviate  $\alpha_1 = \frac{(1+\theta^{-1})^{-1}}{2}$ ,  $\alpha_2 = (2\varrho + 2L_0 + 1)^{-d}$ ,  $\alpha_3 = h\varepsilon_0^{\varrho} \mathbf{P}[\omega_0(|v| = 2) = h]$ , and  $\alpha_4 = \frac{1}{2}\alpha_1\alpha_2\alpha_3\varrho^{-1}$ . The property (2.53) implies that, for some  $C_1 > 0$ ,

$$\mathbf{P}[\text{br}(\zeta_{\varphi_{\lfloor \alpha_1 \alpha_2 n \rfloor}}, \varphi_{\lfloor \alpha_1 \alpha_2 n \rfloor}) \geq \alpha_4 n] \geq 1 - e^{-C_1 n}.$$

So, using (2.50) and (2.52) together with the elementary inequality  $\mathbf{P}[A \mid B] \geq 1 - \frac{\mathbf{P}[A^c]}{\mathbf{P}[B]}$ , we obtain for some  $C_2 > 0$  that

$$\begin{aligned} \mathbf{P}[\text{br}(\zeta_n, n) \geq \alpha_4 n] &\geq \mathbf{P}[\text{br}(\zeta_n, n) \geq \alpha_4 n \mid |U_n| \geq \alpha_1 n] \mathbf{P}[|U_n| \geq \alpha_1 n] \\ &\geq \mathbf{P}[\text{br}(\zeta_{\varphi_{\lfloor \alpha_1 \alpha_2 n \rfloor}}, \varphi_{\lfloor \alpha_1 \alpha_2 n \rfloor}) \geq \alpha_4 n \mid |U_n| \geq \alpha_1 n] \\ &\quad \times \mathbf{P}[|U_n| \geq \alpha_1 n] \\ &\geq C_2. \end{aligned}$$

Therefore, with  $\mathbb{P}$ -probability at least  $C_3 = C_2/2$ ,

$$\mathbb{P}_\omega[\text{br}(\zeta_n, n) \geq \alpha_4 n] \geq C_3.$$

Let  $\hat{\mathcal{F}}_n$  be the sigma-algebra generated by the branching random walk up to time  $n$ . Applying (2.51), we obtain that, for such  $\omega$ 's,

$$\mathbb{P}_\omega[\text{br}(\zeta_n, n) \geq \alpha_4 n \mid \hat{\mathcal{F}}_n] = \sum_{i: \text{br}(i, n) \geq \alpha_4 n} 2^{-\text{br}(i, n)} \leq 2^{-\alpha_4 n} \mathcal{Z}_n^0,$$

so, taking expectations,  $\mathbb{E}_\omega \mathcal{Z}_n^0 \geq C_3 2^{\alpha_4 n}$ . As observed in the beginning of this section, this proves (1.7).

Now, it remains only to prove (1.8). Since

$$\ln \max_{y \in \mathcal{K}_{L_0 n}} \eta_n^0(y) \leq \ln \mathcal{Z}_n^0 \leq d \ln(2L_0 n + 1) + \ln \max_{y \in \mathcal{K}_{L_0 n}} \eta_n^0(y)$$

(note that  $|\mathcal{K}_{L_0 n}| < (2L_0 n + 1)^d$ ), the property (1.8) follows from Theorem 1.7.  $\square$

## References

- O. S. M. Alves, F. P. Machado and S. Yu. Popov. The shape theorem for the frog model. *Ann. Appl. Probab.* **12** (2), 533–546 (2002).
- P. Antal. Enlargement of obstacles for the simple random walk. *Ann. Probab.* **23**, 1061–1101 (1995).
- K. B. Athreya and S. Karlin. Branching processes with random environments II: limit theorems. *Ann. Math. Stat.* **42** (6), 1843–1858 (1971).
- J.-B. Baillon, P. Clément, A. Greven and F. den Hollander. A variational approach to branching random walk in random environment. *Ann. Probab.* **21**, 290–317 (1993).
- J. Biggins. The asymptotic shape of the branching random walk. *Adv. Appl. Probab.* **10**, 62–84 (1978).
- M. Bramson and D. Griffeath. On the Williams-Bjerknes tumor growth model II. *Math. Proc. Cambridge Philos. Soc.* **88**, 339–357 (1980).
- F. Comets, M. V. Menshikov and S. Yu. Popov. One-dimensional branching random walk in random environment: classification. *Markov Process. Relat. Fields* **4** (4), 465–477 (1998).
- F. Comets and S. Yu. Popov. On multidimensional branching random walks in random environment. *Ann. Probab.* **35** (1), 68–114 (2007).
- F. Comets and O. Zeitouni. A law of large numbers for random walks in random mixing environments. *Ann. Probab.* **32** (1B), 880–914 (2004).
- F. den Hollander, M. V. Menshikov and S. Yu. Popov. A note on transience versus recurrence for a branching random walk in random environment. *J. Statist. Phys.* **95** (3–4), 587–614 (1999).
- R. Durrett and D. Griffeath. Contact processes in several dimensions. *Z. Wahrsch. Verw. Gebiete* **59** (4), 535–552 (1982).
- J. Engländer. Branching Brownian motion with ‘mild’ Poissonian obstacles (2005). Preprint. ArXiv math.PR/0508585.
- N. Gantert and S. Müller. The critical branching random walk is transient. *Markov Processes Relat. Fields* **12** (4), 805–814 (2006).
- J. Gärtner, W. König and S. Molchanov. Geometric characterization of intermittency in the parabolic Anderson model. *Ann. Probab.* **35**, 439–499 (2007).

- A. Greven and F. den Hollander. Branching random walk in random environment: phase transitions for local and global growth rates. *Probab. Theory Related Fields* **91**, 195–249 (1992).
- C. Laredo and A. Rouault. Grandes déviations, dynamique de populations et phénomènes malthusiens. *Ann. inst. H. Poincaré Sect. B* **19**, 323–350 (1983).
- T. M. Liggett. *Interacting Particle Systems*. Springer-Verlag (1985).
- F. P. Machado and S. Yu. Popov. One-dimensional branching random walk in a Markovian random environment. *J. Appl. Probab.* **37** (4), 1157–1163 (2000).
- F. P. Machado and S. Yu. Popov. Branching random walk in random environment on trees. *Stochastic Process Appl.* **106** (1), 95–106 (2003).
- S. Müller. A criterion for transience of multidimensional branching random walk in random environment (2007a). Preprint. arXiv.org: 0705.1874.
- S. Müller. Recurrence and transience for branching random walks in an iid random environment (2007b). To appear in *Markov Processes Relat. Fields*.
- J. M. Steele. Kingman’s subadditive ergodic theorem. *Ann. Inst. H. Poincaré Probab. Statist.* **25** (1), 93–98 (1989).
- A. S. Sznitman. Brownian motion with a drift in a Poissonian potential. *Comm. Pure Appl. Math.* **47**, 1283–1318 (1994).
- A. S. Sznitman. Brownian motion, obstacles and random media. *Springer-Verlag, Berlin* (1998).
- D. Tanny. Limit theorems for branching processes in a random environment. *Ann. Probab.* **5** (1), 100–116 (1977).
- R. van der Hofstad, W. König and P. Mörters. The universality classes in the parabolic Anderson model. *Commun. Math. Phys.* **267**, 307–353 (2006).
- S. R. S. Varadhan. Random walks in a random environment. *Proc. Indian Acad. Sci. Math. Sci.* **114**, 309–318 (2004).
- S. Volkov. Branching random walk in random environment: fully quenched case. *Markov Processes Relat. Fields* **7** (2), 349–353 (2001).
- O. Zeitouni. Random walks in random environment. In *Lecture Notes Math.*, volume 1837, pages 190–312. Springer, Berlin (2004).
- M. Zerner. Lyapounov exponents and quenched large deviations for multidimensional random walk in random environment. *Ann. Probab.* **26**, 1446–1476 (1998).